

CHAPTER 27
FREEWAY WEAVING: SUPPLEMENTAL

CONTENTS

1. INTRODUCTION.....27-1

2. EXAMPLE PROBLEMS.....27-2

 Example Problem 1: LOS of a Major Weaving Segment27-2

 Example Problem 2: LOS for a Ramp Weave27-7

 Example Problem 3: LOS of a Two-Sided Weaving Segment27-11

 Example Problem 4: Design of a Major Weaving Segment for a
 Desired LOS27-16

 Example Problem 5: Constructing a Service Volume Table for a
 Weaving Segment.....27-22

 Example Problem 6: LOS of an ML Access Segment with Cross-
 Weaving.....27-27

 Example Problem 7: ML Access Segment with Downstream Off-Ramp...27-32

3. ALTERNATIVE TOOL EXAMPLES FOR WEAVING SEGMENTS27-37

 Determining the Weaving Segment Capacity27-38

 Effect of Demand on Performance27-39

 Effect of Queue Backup from a Downstream Signal on the Exit Ramp27-40

LIST OF EXHIBITS

Exhibit 27-1 List of Example Problems for Weaving Segment Analysis	27-2
Exhibit 27-2 Example Problem 1: Major Weaving Segment Data	27-2
Exhibit 27-3 Example Problem 1: Determination of Configuration Variables	27-4
Exhibit 27-4 Example Problem 1: Capacity of Entry and Exit Roadways	27-5
Exhibit 27-5 Example Problem 2: Ramp-Weave Segment Data.....	27-7
Exhibit 27-6 Example Problem 2: Configuration Characteristics	27-9
Exhibit 27-7 Example Problem 2: Capacity of Entry and Exit Legs	27-10
Exhibit 27-8 Example Problem 3: Two-Sided Weaving Segment Data.....	27-12
Exhibit 27-9 Example Problem 3: Configuration Characteristics	27-14
Exhibit 27-10 Example Problem 3: Capacity of Entry and Exit Legs	27-15
Exhibit 27-11 Example Problem 4: Major Weaving Segment Data	27-17
Exhibit 27-12 Example Problem 4: Trial Design 1	27-18
Exhibit 27-13 Example Problem 4: Trial Design 2	27-20
Exhibit 27-14 Example Problem 5: Maximum Density Thresholds for LOS A–D.....	27-23
Exhibit 27-15 Example Problem 5: Service Flow Rates (pc/h) Under Ideal Conditions (<i>SFI</i>)	27-25
Exhibit 27-16 Example Problem 5: Service Flow Rates (veh/h) Under Prevailing Conditions (<i>SF</i>)	27-25
Exhibit 27-17 Example Problem 5: Service Volumes (veh/h) Under Prevailing Conditions (<i>SV</i>).....	27-26
Exhibit 27-18 Example Problem 5: Daily Service Volumes (veh/day) Under Prevailing Conditions (<i>DSV</i>).....	27-26
Exhibit 27-19 Example Problem 6: ML Access Segment with Cross- Weaving	27-27
Exhibit 27-20 Example Problem 6: Hourly Flow Rates After PHF Is Applied	27-29
Exhibit 27-21 Example Problem 6: Configuration Characteristics	27-29
Exhibit 27-22 Example Problem 6: Capacity of Entry and Exit Legs	27-31
Exhibit 27-23 Example Problem 7: ML Access Segment Data	27-32
Exhibit 27-24 Example Problem 7: Weaving Flows for Managed Lane Segment.....	27-33
Exhibit 27-25 Link–Node Structure for the Simulated Weaving Segment.....	27-37
Exhibit 27-26 Input Data for Various Demand Levels (veh/h)	27-37
Exhibit 27-27 Determining the Capacity of a Weaving Segment by Simulation.....	27-38

Exhibit 27-28 Simulated Effect of Demand Volume on Weaving Segment
Capacity and Speed27-39

Exhibit 27-29 Exit Ramp Signal Operating Parameters27-40

Exhibit 27-30 Deterioration of Weaving Segment Operation due to Queue
Backup from a Traffic Signal.....27-41

Exhibit 27-31 Effect of Demand on Weaving Segment Throughput with
Exit Ramp Backup27-41

Exhibit 27-32 Effect of Demand on Exit Ramp Throughput with Signal
Queuing27-42



1. INTRODUCTION

Chapter 27 is the supplemental chapter for Chapter 13, Freeway Weaving Segments, which is found in Volume 2 of the *Highway Capacity Manual* (HCM). Section 2 provides seven example problems demonstrating the application of the Chapter 13 core methodology and its extension to freeway managed lanes. Section 3 presents examples of applying alternative tools to the analysis of freeway weaving sections to address limitations of the Chapter 13 methodology.



VOLUME 4: APPLICATIONS
GUIDE

- 25. Freeway Facilities: Supplemental
- 26. Freeway and Highway Segments: Supplemental
- 27. Freeway Weaving: Supplemental**
- 28. Freeway Merges and Diverges: Supplemental
- 29. Urban Street Facilities: Supplemental
- 30. Urban Street Segments: Supplemental
- 31. Signalized Intersections: Supplemental
- 32. STOP-Controlled Intersections: Supplemental
- 33. Roundabouts: Supplemental
- 34. Interchange Ramp Terminals: Supplemental
- 35. Pedestrians and Bicycles: Supplemental
- 36. Concepts: Supplemental
- 37. ATDM: Supplemental

2. EXAMPLE PROBLEMS

The example problems in this section illustrate various applications of the freeway weaving segment methodology detailed in Chapter 13. Exhibit 27-1 lists the example problems included. Example problem results from intermediate and final calculations were derived by using a handheld scientific calculator with 12-digit precision. For displaying equation results in text, the results were appropriately rounded. Users may obtain slightly different results if rounded parameters are used in intermediate and final calculations.

Exhibit 27-1
List of Example Problems for Weaving Segment Analysis

Example Problem	Description	Application
1	LOS of a major weaving segment	Operational analysis
2	LOS for a ramp weave	Operational analysis
3	LOS of a two-sided weaving segment	Operational analysis
4	Design of a major weaving segment for a desired LOS	Design analysis
5	Service volume table construction	Planning analysis
6	LOS of an ML access segment with cross-weaving	Operational analysis
7	ML access segment with downstream off-ramp	Operational analysis

EXAMPLE PROBLEM 1: LOS OF A MAJOR WEAVING SEGMENT

The Weaving Segment

The subject of this operational analysis is a major weaving segment on an urban freeway under nonsevere weather conditions and without incidents, as shown in Exhibit 27-2. The short length of the weaving segment L_S is 1,500 ft.

Exhibit 27-2
Example Problem 1: Major Weaving Segment Data

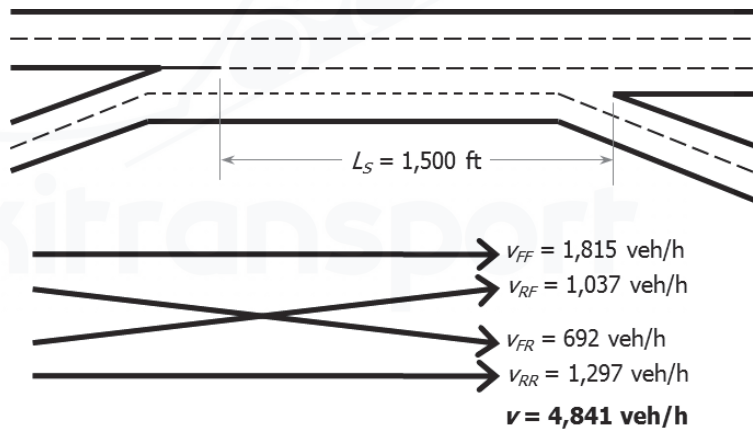

What is the level of service (LOS) and capacity of the weaving segment shown in Exhibit 27-2?

The Facts

In addition to the information contained in Exhibit 27-2, the following characteristics of the weaving segment are known:

PHF = 0.91 (for all movements);

Heavy vehicles = 5% trucks;

Driver population = regular commuters;

Free-flow speed (FFS) = 65 mi/h; ramp FFS = 50 mi/h;
 $c_{IFL} = 2,350$ pc/h/ln (for FFS = 65 mi/h);
 $ID = 0.8$ interchange/mi; and
 Terrain = level.

Note that the ideal freeway capacity per lane c_{IFL} is the capacity of a basic freeway segment, where the FFS is 65 mi/h. It is drawn from the methodology of Chapter 12, Basic Freeway and Multilane Highway Segments.

Comments

Chapter 12, Basic Freeway and Multilane Highway Segments, must be consulted to find appropriate values for the heavy-vehicle adjustment factor f_{HV} . Chapter 26, Section 2, should be consulted if the driver population includes a significant proportion of noncommuters.

All input parameters have been specified, so default values are not needed. Demand volumes are given in vehicles per hour under prevailing conditions. These must be converted to passenger cars per hour under equivalent ideal conditions for use with the weaving methodology. The weaving segment length must be compared with the maximum length for weaving analysis to determine whether the Chapter 13 methodology is applicable. The capacity of the weaving segment is estimated and compared with the total demand flow to determine whether LOS F exists. Lane-changing rates are calculated to allow estimations of speed for weaving and nonweaving flows. Average overall speed and density are computed and compared with the criteria of Exhibit 13-6 to determine LOS.

Without specific information to the contrary, it is assumed that good weather conditions prevail and that there are no incidents during the analysis period.

Step 1: Input Data

All inputs have been specified in Exhibit 27-2 and the Facts section of the problem statement.

Step 2: Adjust Volume

Equation 13-1 is used to convert the four component demand volumes to flow rates under equivalent ideal conditions. Chapter 12 is consulted to obtain a value of E_T (2.0 for level terrain). From Chapter 12, the heavy-vehicle adjustment factor is computed as

$$f_{HV} = \frac{1}{1 + P_T(E_T - 1)} = \frac{1}{1 + 0.05(2 - 1)} = 0.952$$

Equation 13-1 is now used to convert all demand volumes:

$$v_i = \frac{V_i}{PHF \times f_{HV}}$$

$$v_{FF} = \frac{1,815}{0.91 \times 0.952} = 2,094 \text{ pc/h}$$

$$v_{FR} = \frac{692}{0.91 \times 0.952} = 798 \text{ pc/h}$$

$$v_{RF} = \frac{1,037}{0.91 \times 0.952} = 1,197 \text{ pc/h}$$

$$v_{RR} = \frac{1,297}{0.91 \times 0.952} = 1,497 \text{ pc/h}$$

Then

$$v_W = 798 + 1,197 = 1,995 \text{ pc/h}$$

$$v_{NW} = 2,094 + 1,497 = 3,591 \text{ pc/h}$$

$$v = 1,995 + 3,591 = 5,586 \text{ pc/h}$$

$$VR = \frac{1,995}{5,586} = 0.357$$

Step 3: Determine Configuration Characteristics

The configuration is examined to determine the values of LC_{RF} , LC_{FR} , and N_{WL} . These determinations are illustrated in Exhibit 27-3. From these values, the minimum number of lane changes by weaving vehicles, LC_{MIN} , is then computed by using Equation 13-2.

Exhibit 27-3
Example Problem 1:
Determination of
Configuration Variables

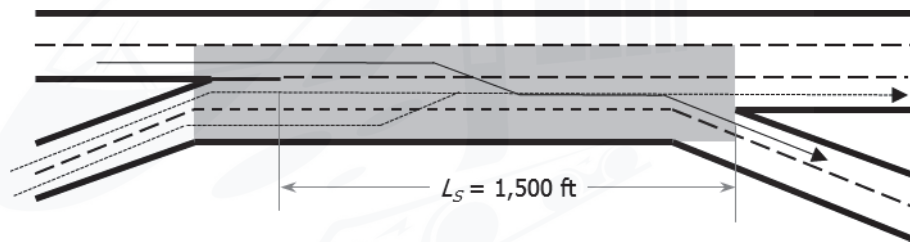

Exhibit 27-3 indicates that ramp-to-freeway vehicles can execute their weaving maneuver without making a lane change (if they so desire). Thus, $LC_{RF} = 0$. Freeway-to-ramp vehicles must make at least one lane change to complete their desired maneuver. Thus, $LC_{FR} = 1$. If optional lane changes are considered, weaving movements can be accomplished with one or no lane changes from both entering ramp lanes and from the rightmost freeway lane. Thus, $N_{WL} = 3$.

Equation 13-2 can now be applied:

$$LC_{MIN} = (LC_{RF} \times v_{RF}) + (LC_{FR} \times v_{FR})$$

$$LC_{MIN} = (0 \times 1,197) + (1 \times 798) = 798 \text{ lc/h}$$

Step 4: Determine Maximum Weaving Length

The maximum length over which weaving movements may exist is determined by Equation 13-4. The determination is case-specific, and the result is valid only for the case under consideration:

$$L_{MAX} = [5,728(1 + VR)^{1.6}] - (1,566N_{WL})$$

$$L_{MAX} = [5,728(1 + 0.357)^{1.6}] - (1,566 \times 3) = 4,639 \text{ ft}$$

Since the maximum length is significantly greater than the actual segment length of 1,500 ft, weaving operations do exist, and the analysis may continue with the weaving analysis methodology.

Step 5: Determine Weaving Segment Capacity

Capacity may be controlled by one of two factors: operations reaching a maximum density of 43 pc/mi/ln or by the weaving demand flow rate reaching 3,500 pc/h (for a weaving segment with $N_{WL} = 3$). Equations 13-5 through 13-10 are used to make these determinations.

Capacity Controlled by Density

$$c_{IWL} = c_{IFL} - [438.2(1 + VR)^{1.6}] + (0.0765L_S) + (119.8N_{WL})$$

$$c_{IWL} = 2,350 - [438.2(1 + 0.357)^{1.6}] + (0.0765 \times 1,500) + (119.8 \times 3)$$

$$c_{IWL} = 2,110 \text{ pc/h/ln}$$

$$c_W = c_{IWL} \times N \times f_{HV}$$

$$c_W = 2,110 \times 4 \times 0.952 = 8,038 \text{ veh/h}$$

Capacity Controlled by Maximum Weaving Flow Rate

$$c_{IW} = \frac{3,500}{VR} = \frac{3,500}{0.357} = 9,800 \text{ pc/h}$$

$$c_W = 9,800 \times 0.952 \times 1 = 9,333 \text{ veh/h}$$

Note that the methodology computes the capacity controlled by density in passenger cars per hour per lane, while the capacity controlled by maximum weaving flow rate is computed in passenger cars per hour. After conversion, however, both are in units of vehicles per hour.

The controlling value is the smaller of the two, or 8,038 veh/h. Since the total demand flow rate is only 5,320 veh/h, the capacity is clearly sufficient, and this situation will not result in LOS F.

Capacity of Input and Output Roadways

The capacity of the entry and exit roadways should also be checked, although this is rarely a factor in weaving segment operation. Basic capacities for the freeway entry and exit legs (with FFS = 65 mi/h) are taken from Chapter 12, while the capacity for the two-lane entry and exit ramps (with ramp FFS = 50 mi/h) is taken from Chapter 14. The comparisons are shown in Exhibit 27-4.

Leg	Demand Flow (pc/h)	Capacity (pc/h)
Freeway entry	2,094 + 798 = 2,892	2 × 2,350 = 4,700
Freeway exit	1,197 + 2,094 = 3,291	2 × 2,350 = 4,700
Ramp entry	1,197 + 1,497 = 2,694	4,100
Ramp exit	798 + 1,497 = 2,295	4,100

Exhibit 27-4
Example Problem 1: Capacity of Entry and Exit Roadways

As can be seen, capacity is sufficient on each of the entry and exit roadways and will therefore not affect operations within the weaving segment.

Step 6: Determine Lane-Changing Rates

Equations 13-11 through 13-17 are used to estimate the lane-changing rates of weaving and nonweaving vehicles in the weaving segment. In turn, these will be used to estimate weaving and nonweaving vehicle speeds.

Weaving Vehicle Lane-Changing Rate

$$LC_W = LC_{MIN} + 0.39[(L_S - 300)^{0.5} N^2 (1 + ID)^{0.8}]$$

$$LC_W = 798 + 0.39[(1,500 - 300)^{0.5} (4^2) (1 + 0.8)^{0.8}] = 1,144 \text{ lc/h}$$

Nonweaving Vehicle Lane-Changing Rate

$$I_{NW} = \frac{L_S \times ID \times v_{NW}}{10,000}$$

$$I_{NW} = \frac{1,500 \times 0.8 \times 3,591}{10,000} = 431 < 1,300$$

$$LC_{NW} = LC_{NW1} = (0.206v_{NW}) + (0.542L_S) - (192.6N)$$

$$LC_{NW} = (0.206 \times 3,591) + (0.542 \times 1,500) - (192.6 \times 4) = 782 \text{ lc/h}$$

Total Lane-Changing Rate

$$LC_{ALL} = LC_W + LC_{NW} = 1,144 + 782 = 1,926 \text{ lc/h}$$

Step 7: Determine Average Speeds of Weaving and Nonweaving Vehicles

The average speeds of weaving and nonweaving vehicles are computed from Equation 13-18 through Equation 13-21:

$$W = 0.226 \left(\frac{LC_{ALL}}{L_S} \right)^{0.789}$$

$$W = 0.226 \left(\frac{1,926}{1,500} \right)^{0.789} = 0.275$$

Then

$$S_W = 15 + \left(\frac{FFS \times SAF - 15}{1 + W} \right)$$

$$S_W = 15 + \left(\frac{65 \times 1 - 15}{1 + 0.275} \right) = 54.2 \text{ mi/h}$$

and

$$S_{NW} = FFS \times SAF - (0.0072LC_{MIN}) - \left(0.0048 \frac{v}{N} \right)$$

$$S_{NW} = 65 \times 1 - (0.0072 \times 798) - \left(0.0048 \frac{5,586}{4} \right) = 52.5 \text{ mi/h}$$

Equation 13-22 is now used to compute the average speed of all vehicles in the segment:

$$S = \frac{v_W + v_{NW}}{\left(\frac{v_W}{S_W} \right) + \left(\frac{v_{NW}}{S_{NW}} \right)}$$

$$S = \frac{3,591 + 1,995}{\left(\frac{3,591}{52.5} \right) + \left(\frac{1,995}{54.2} \right)} = 53.1 \text{ mi/h}$$

Step 8: Determine LOS

Equation 13-23 is used to convert the average speed of all vehicles in the segment to an average density:

$$D = \frac{(v/N)}{S} = \frac{(5,586/4)}{53.1} = 26.3 \text{ pc/mi/ln}$$

The resulting density of 26.3 pc/mi/ln is compared with the LOS criteria of Exhibit 13-6. The LOS is C, since the density is within the specified range of 20 to 28 pc/h/ln for that level.

Discussion

As indicated by the results, this weaving segment operates at LOS C, with an average speed of 53.1 mi/h for all vehicles. Weaving vehicles travel a bit faster than nonweaving vehicles, primarily because the configuration favors weaving vehicles and many weaving maneuvers can be made without a lane change. In turn, the method estimates that nonweaving vehicles are affected by the weave turbulence, which results in a drop in speed of those movements. The demand flow rate of 5,320 veh/h is considerably less than the capacity of the segment, 8,038 veh/h. In other words, demand can grow significantly before reaching the capacity of the segment.

EXAMPLE PROBLEM 2: LOS FOR A RAMP WEAVE

The Weaving Segment

The weaving segment that is the subject of this operational analysis, under nonsevere weather conditions and without incidents, is shown in Exhibit 27-5. It is a typical ramp-weave segment.

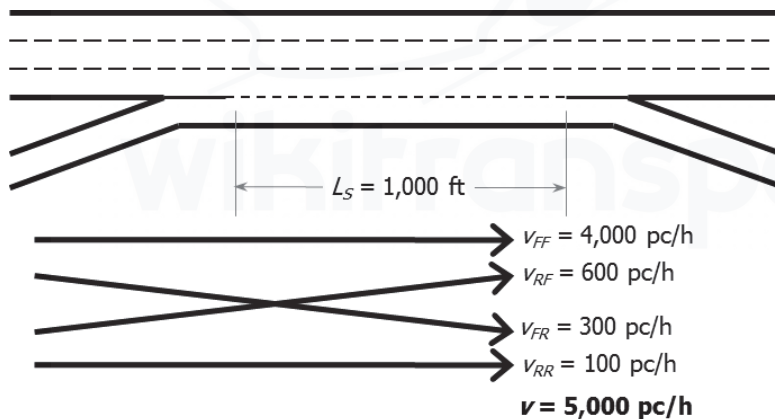

Exhibit 27-5
Example Problem 2: Ramp-Weave Segment Data

What is the capacity of the weaving segment of Exhibit 27-5, and at what LOS is it expected to operate with the demand flow rates as shown?

The Facts

In addition to the information given in Exhibit 27-5, the following facts are known about the subject weaving segment:

PHF = 1.00 (demands stated as flow rates);

Heavy vehicles = 0%; demand given in passenger car equivalents;

Driver population = regular commuters;
 FFS = 75 mi/h; RFFS = 40 mi/h;
 $c_{IFL} = 2,400$ pc/h/ln (for FFS = 75 mi/h);
 $ID = 1.0$ int/mi; and
 Terrain = level.

Comments

Because the demands have been specified as flow rates in passenger cars per hour under equivalent ideal conditions, Chapter 12 does not have to be consulted to obtain appropriate adjustment factors.

Several of the computational steps related to converting demand volumes to flow rates under equivalent ideal conditions are unnecessary, since demands are already specified in that form. Lane-changing characteristics will be estimated. The maximum length for weaving operations in this case will be estimated and compared with the actual length of the segment. The capacity of the segment will be estimated and compared with the demand to determine whether LOS F exists. If it does not, component flow speeds will be estimated and averaged. A density will be estimated and compared with the criteria of Exhibit 13-6 to determine the expected LOS.

Step 1: Input Data

All input data are stated in Exhibit 27-5 and the Facts section.

Step 2: Adjust Volume

Because all demands are stated as flow rates in passenger cars per hour under equivalent ideal conditions, no further conversions are necessary. Key volume parameters are as follows:

$$\begin{aligned} v_{FF} &= 4,000 \text{ pc/h} \\ v_{FR} &= 600 \text{ pc/h} \\ v_{RF} &= 300 \text{ pc/h} \\ v_{RR} &= 100 \text{ pc/h} \\ v_W &= 600 + 300 = 900 \text{ pc/h} \\ v_{NW} &= 4,000 + 100 = 4,100 \text{ pc/h} \\ v &= 4,100 + 900 = 5,000 \text{ pc/h} \\ VR &= \frac{900}{5,000} = 0.180 \end{aligned}$$

Step 3: Determine Configuration Characteristics

The configuration is examined to determine the values of LC_{RF} , LC_{FR} , and N_{WL} . These determinations are illustrated in Exhibit 27-6. From these values, the minimum number of lane changes by weaving vehicles LC_{MIN} is then computed by using Equation 13-2.

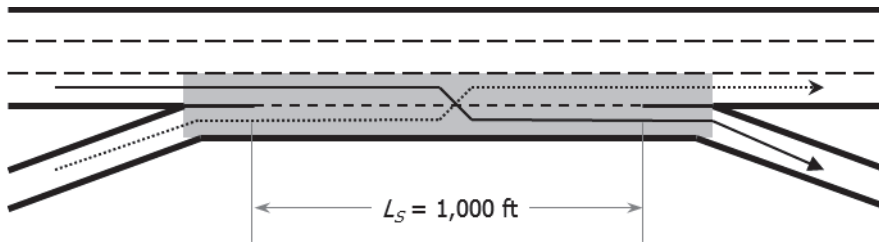

Exhibit 27-6
Example Problem 2:
Configuration Characteristics

From Exhibit 27-6, it is clear that all ramp-to-freeway vehicles must make at least one lane change ($LC_{RF} = 1$) and that all freeway-to-ramp vehicles must make at least one lane change ($LC_{FR} = 1$). It is also clear that a weaving maneuver can only be completed with a single lane change from the right lane of the freeway or the auxiliary lane ($N_{WL} = 2$). Then, by using Equation 13-2, LC_{MIN} is computed as

$$LC_{MIN} = (LC_{RF} \times v_{RF}) + (LC_{FR} \times v_{FR})$$

$$LC_{MIN} = (1 \times 600) + (1 \times 300) = 900 \text{ lc/h}$$

Step 4: Determine Maximum Weaving Length

The maximum length over which weaving operations may exist for the segment described is found by using Equation 13-4:

$$L_{MAX} = [5,728(1 + VR)^{1.6}] - (1,566N_{WL})$$

$$L_{MAX} = [5,728(1 + 0.180)^{1.6}] - (1,566 \times 2) = 4,333 \text{ ft} > 1,000 \text{ ft}$$

Since the maximum length for weaving operations significantly exceeds the actual length, this is a weaving segment, and the analysis continues.

Step 5: Determine Weaving Segment Capacity

The capacity of the weaving segment is controlled by one of two limiting factors: density reaches 43 pc/mi/ln or weaving demand reaches 2,400 pc/h for the configuration of Exhibit 27-5 (a ramp weave with $N_{WL} = 2$).

Capacity Limited by Density

The capacity limited by reaching a density of 43 pc/mi/ln is estimated by using Equation 13-5 and Equation 13-6:

$$c_{IWL} = c_{IFL} - [438.2(1 + VR)^{1.6}] + (0.0765L_S) + (119.8N_{WL})$$

$$c_{IWL} = 2,400 - [438.2(1 + 0.180)^{1.6}] + (0.0765 \times 1,000) + (119.8 \times 2)$$

$$c_{IWL} = 2,145 \text{ pc/h/ln}$$

$$c_W = c_{IWL} \times N \times f_{HV}$$

$$c_W = 2,145 \times 4 = 8,580 \text{ pc/h}$$

Capacity Limited by Weaving Demand Flow

The capacity limited by the weaving demand flow is estimated by using Equation 13-7 and Equation 13-8:

$$c_{IW} = \frac{2,400}{VR} = \frac{2,400}{0.180} = 13,333 \text{ pc/h}$$

$$c_W = c_{IW} \times f_{HV}$$

$$c_W = 13,333 \times 1 = 13,333 \text{ pc/h}$$

The controlling capacity is the smaller value, or 8,580 pc/h. At this point, the value is usually stated as vehicles per hour. In this case, because inputs were already adjusted and were stated in passenger cars per hour, conversions back to vehicles per hour are not possible.

Since the capacity of the weaving segment is larger than the demand flow rate of 5,000 pc/h, LOS F does not exist, and the analysis may continue.

Capacity of Input and Output Roadways

Although it is rarely a factor in weaving operations, the capacity of input and output roadways should be checked to ensure that no deficiencies exist. There are three input and output freeway lanes (with FFS = 75 mi/h) and one lane on the entrance and exit ramps (with ramp FFS = 35 mi/h). The criteria of Chapter 12 and Chapter 14, respectively, are used to determine the capacity of freeway legs and ramps. Demand flows and capacities are compared in Exhibit 27-7.

Exhibit 27-7
Example Problem 2: Capacity of Entry and Exit Legs

Leg	Demand Flow (pc/h)	Capacity (pc/h)
Freeway entry	4,000 + 300 = 4,300	3 × 2,400 = 7,200
Freeway exit	4,000 + 600 = 4,600	3 × 2,400 = 7,200
Ramp entry	600 + 100 = 700	2,000
Ramp exit	300 + 100 = 400	2,000

The capacity of all input and output roadways is sufficient to accommodate the demand flow rates.

Step 6: Determine Lane-Changing Rates

Equation 13-11 through Equation 13-17 are used to estimate the lane-changing rates of weaving and nonweaving vehicles in the weaving segment. In turn, these will be used to estimate weaving and nonweaving vehicle speeds.

Weaving Vehicle Lane-Changing Rate

$$LC_W = LC_{MIN} + 0.39[(L_S - 300)^{0.5} N^2 (1 + ID)^{0.8}]$$

$$LC_W = 900 + 0.39[(1,000 - 300)^{0.5} (4^2) (1 + 1)^{0.8}] = 1,187 \text{ lc/h}$$

Nonweaving Vehicle Lane-Changing Rate

$$I_{NW} = \frac{L_S \times ID \times v_{NW}}{10,000}$$

$$I_{NW} = \frac{1,000 \times 1 \times 4,100}{10,000} = 410 < 1,300$$

$$LC_{NW} = LC_{NW1} = (0.206v_{NW}) + (0.542L_S) - (192.6N)$$

$$LC_{NW} = (0.206 \times 4,100) + (0.542 \times 1,000) - (192.6 \times 4) = 616 \text{ lc/h}$$

Total Lane-Changing Rate

$$LC_{ALL} = LC_W + LC_{NW} = 1,187 + 616 = 1,803 \text{ lc/h}$$

Step 7: Determine Average Speeds of Weaving and Nonweaving Vehicles

The average speeds of weaving and nonweaving vehicles are computed from Equation 13-18 through Equation 13-21:

$$W = 0.226 \left(\frac{LC_{ALL}}{L_S} \right)^{0.789}$$

$$W = 0.226 \left(\frac{1,803}{1,000} \right)^{0.789} = 0.360$$

Then

$$S_W = 15 + \left(\frac{FFS \times SAF - 15}{1 + W} \right)$$

$$S_W = 15 + \left(\frac{75 \times 1 - 15}{1 + 0.360} \right) = 59.1 \text{ mi/h}$$

and

$$S_{NW} = FFS \times SAF - (0.0072LC_{MIN}) - \left(0.0048 \frac{v}{N} \right)$$

$$S_{NW} = 75 \times 1 - (0.0072 \times 900) - \left(0.0048 \frac{5,000}{4} \right) = 62.5 \text{ mi/h}$$

Equation 13-22 is now used to compute the average speed of all vehicles in the segment:

$$S = \frac{v_W + v_{NW}}{\left(\frac{v_W}{S_W} \right) + \left(\frac{v_{NW}}{S_{NW}} \right)}$$

$$S = \frac{4,100 + 900}{\left(\frac{4,100}{62.5} \right) + \left(\frac{900}{59.1} \right)} = 61.9 \text{ mi/h}$$

Step 8: Determine LOS

The average density in the weaving segment is estimated by using Equation 13-23.

$$D = \frac{(v/N)}{S} = \frac{(5,000/4)}{61.9} = 20.2 \text{ pc/mi/ln}$$

From Exhibit 13-6, this density is within the stated boundaries of LOS C (20 to 28 pc/mi/ln). However, it is very close to the LOS B boundary condition.

Discussion

As noted, the segment is operating well (LOS C) and is close to the LOS B boundary. Weaving and nonweaving speeds are relatively high, suggesting a stable flow. The demand flow rate of 5,000 pc/h is well below the capacity of the segment (8,580 pc/h). Weaving vehicles travel somewhat more slowly than nonweaving vehicles, which is typical of ramp-weave segments, where the vast majority of nonweaving vehicles are running from freeway to freeway.

EXAMPLE PROBLEM 3: LOS OF A TWO-SIDED WEAVING SEGMENT

The Weaving Segment

The weaving segment that is the subject of this example problem is shown in Exhibit 27-8. The analysis assumes no adverse weather effects or incidents in the segment.

Exhibit 27-8
 Example Problem 3: Two-Sided Weaving Segment Data

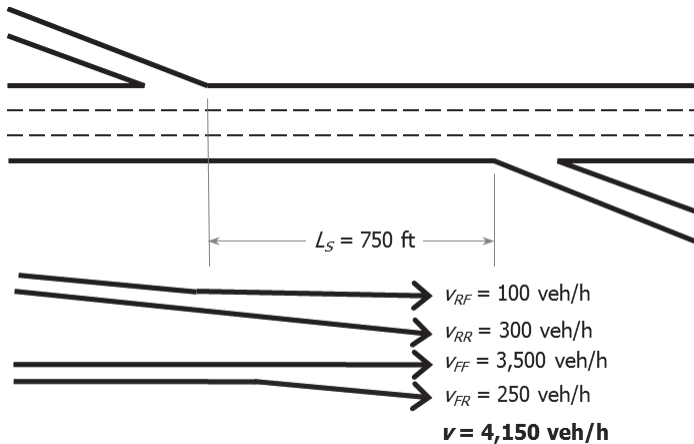

What is the expected LOS and capacity for the weaving segment of Exhibit 27-8?

The Facts

In addition to the information contained in Exhibit 27-8, the following facts concerning the weaving segment are known:

- PHF = 0.94 (all movements);
- Heavy vehicles = 11% trucks;
- Driver population = regular commuters;
- FFS = 60 mi/h; ramp FFS = 30 mi/h;
- $c_{IFL} = 2,300 \text{ pc/h/ln}$ (for FFS = 60 mi/h);
- ID = 2 int/mi; and
- Terrain = rolling.

Comments

Because this example illustrates the analysis of a two-sided weaving segment, several key parameters are different from those for a more typical one-side weaving segment.

In a two-sided weaving segment, only the ramp-to-ramp flow is considered to be a weaving flow. While the freeway-to-freeway flow technically weaves with the ramp-to-ramp flow, the operation of freeway-to-freeway vehicles more closely resembles that of nonweaving vehicles. These vehicles generally make few lane changes as they move through the segment in a freeway lane. This segment is in a busy urban corridor with a high interchange density and a relatively low FFS for the freeway.

Solution steps are the same as in the first two example problems. However, since the segment is a two-sided weaving segment, some of the key values will be computed differently, as described in the methodology.

Component demand volumes will be converted to equivalent flow rates in passenger cars per hour under ideal conditions, and key demand parameters will be calculated. A maximum weaving length will be estimated to determine

whether a weaving analysis is appropriate. The capacity of the weaving segment will be estimated to determine whether LOS F exists. In addition, the segment density will be estimated to evaluate whether LOS F exists. If it does not, lane-changing parameters, speeds, density, and LOS will be estimated.

Step 1: Input Data

All information concerning this example problem is given in Exhibit 27-8 and the Facts section.

Step 2: Adjust Volume

To convert demand volumes to flow rates under equivalent ideal conditions, Chapter 12 must be consulted to obtain the following values:

$$E_T = 3.0 \text{ (for rolling terrain)}$$

Then

$$f_{HV} = \frac{1}{1 + P_T(E_T - 1)} = \frac{1}{1 + 0.11(3 - 1)} = 0.82$$

Component demand volumes may now be converted to flow rates under equivalent ideal conditions:

$$v_i = \frac{V_i}{PHF \times f_{HV}}$$

$$v_{FF} = \frac{3,500}{0.94 \times 0.82} = 4,541 \text{ pc/h}$$

$$v_{FR} = \frac{250}{0.94 \times 0.82} = 324 \text{ pc/h}$$

$$v_{RF} = \frac{100}{0.94 \times 0.82} = 130 \text{ pc/h}$$

$$v_{RR} = \frac{300}{0.94 \times 0.82} = 389 \text{ pc/h}$$

Because this is a two-sided weaving segment, the only weaving flow is the ramp-to-ramp flow. All other flows are treated as nonweaving. Then

$$v_W = 389 \text{ pc/h}$$

$$v_{NW} = 4,541 + 324 + 130 = 4,995 \text{ pc/h}$$

$$v = 4,995 + 389 = 5,384 \text{ pc/h}$$

$$VR = 389/5,384 = 0.072$$

Exhibit 27-9
 Example Problem 3:
 Configuration Characteristics

Step 3: Determine Configuration Characteristics

The determination of configuration characteristics is also affected by the existence of a two-sided weaving segment. Exhibit 27-9 illustrates the determination of LC_{RR} , the key variable for two-sided weaving segments. For such segments, $N_{WL} = 0$ by definition.

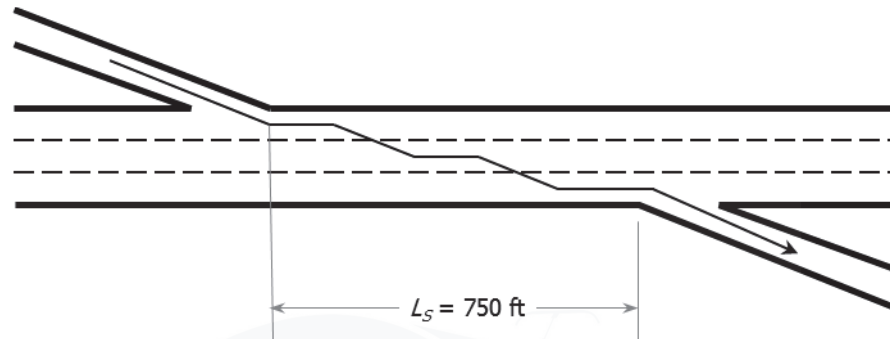

From Exhibit 27-9, ramp-to-ramp vehicles must make two lane changes to complete their desired weaving maneuver. Then

$$LC_{MIN} = (LC_{RR} \times v_{RR}) = 2 \times 389 = 778 \text{ lc/h}$$

Step 4: Determine Maximum Weaving Length

The maximum length of a weaving segment for this configuration and demand scenario is estimated by using Equation 13-4:

$$L_{MAX} = [5,728(1 + VR)^{1.6}] - (1,566N_{WL})$$

$$L_{MAX} = [5,728(1 + 0.072)^{1.6}] - (1,566 \times 0) = 6,405 \text{ ft} > 750 \text{ ft}$$

In this two-sided configuration, the impacts of weaving on operations could be felt at lengths as long as 6,405 ft. Since this is significantly greater than the actual length of 750 ft, the segment clearly operates as a weaving segment, and therefore the methodology of this chapter should be applied.

Step 5: Determine Weaving Segment Capacity

The capacity of a two-sided weaving segment can only be estimated when a density of 43 pc/h/ln is reached. This estimation is made by using Equation 13-5 and Equation 13-6:

$$c_{IWL} = c_{IFL} - [438.2(1 + VR)^{1.6}] + (0.0765L_S) + (119.8N_{WL})$$

$$c_{IWL} = 2,300 - [438.2(1 + 0.072)^{1.6}] + (0.0765 \times 750) + (119.8 \times 0)$$

$$c_{IWL} = 1,867 \text{ pc/h/ln}$$

$$c_W = c_{IWL} \times N \times f_{HV}$$

$$c_W = 1,867 \times 3 \times 0.816 = 4,573 \text{ veh/h} > 4,150 \text{ veh/h}$$

Because the capacity of the segment exceeds the demand volume (in vehicles per hour), LOS F is not expected, and the analysis may be continued.

The capacity of input and output roadways must also be checked. The freeway input and output roadways have three lanes and a capacity of $2,300 \times 3 = 6,900$ pc/h (Chapter 12). The one-lane ramps (with ramp FFS = 30 mi/h) have a capacity of 1,900 pc/h (Chapter 14). Exhibit 27-10 compares these capacities with the demand flow rates (in pc/h).

Leg	Demand Flow (pc/h)	Capacity (pc/h)
Freeway entry	$4,541 + 324 = 4,865$	6,900
Freeway exit	$4,541 + 130 = 4,671$	6,900
Ramp entry	$130 + 389 = 519$	1,900
Ramp exit	$324 + 389 = 713$	1,900

Exhibit 27-10

Example Problem 3: Capacity of Entry and Exit Legs

All demands are below their respective capacities.

Step 6: Determine Lane-Changing Rates

Equation 13-11 through Equation 13-17 are used to estimate the lane-changing rates of weaving and nonweaving vehicles in the weaving segment. In turn, these will be used to estimate weaving and nonweaving vehicle speeds.

Weaving Vehicle Lane-Changing Rate

$$LC_W = LC_{MIN} + 0.39[(L_S - 300)^{0.5} N^2 (1 + ID)^{0.8}]$$

$$LC_W = 778 + 0.39[(750 - 300)^{0.5} (3^2)(1 + 2)^{0.8}] = 960 \text{ lc/h}$$

Nonweaving Vehicle Lane-Changing Rate

$$I_{NW} = \frac{L_S \times ID \times v_{NW}}{10,000}$$

$$I_{NW} = \frac{750 \times 2 \times 5,015}{10,000} = 752 < 1,300$$

$$LC_{NW} = LC_{NW1} = (0.206v_{NW}) + (0.542L_S) - (192.6N)$$

$$LC_{NW} = (0.206 \times 5,015) + (0.542 \times 750) - (192.6 \times 3) = 861 \text{ lc/h}$$

Total Lane-Changing Rate

$$LC_{ALL} = LC_W + LC_{NW} = 960 + 861 = 1,821 \text{ lc/h}$$

Step 7: Determine Average Speeds of Weaving and Nonweaving Vehicles

The average speeds of weaving and nonweaving vehicles are computed from Equation 13-18 through Equation 13-21:

$$W = 0.226 \left(\frac{LC_{ALL}}{L_S} \right)^{0.789}$$

$$W = 0.226 \left(\frac{1,821}{750} \right)^{0.789} = 0.455$$

Then

$$S_W = 15 + \left(\frac{FFS \times SAF - 15}{1 + W} \right)$$

$$S_W = 15 + \left(\frac{60 \times 1 - 15}{1 + 0.455} \right) = 45.9 \text{ mi/h}$$

and

$$S_{NW} = FFS \times SAF - (0.0072LC_{MIN}) - \left(0.0048 \frac{v}{N}\right)$$

$$S_{NW} = 60 \times 1 - (0.0072 \times 778) - \left(0.0048 \frac{5,384}{3}\right) = 45.8 \text{ mi/h}$$

Equation 13-22 is now used to compute the average speed of all vehicles in the segment:

$$S = \frac{v_W + v_{NW}}{\left(\frac{v_W}{S_W}\right) + \left(\frac{v_{NW}}{S_{NW}}\right)}$$

$$S = \frac{389 + 4,995}{\left(\frac{389}{45.9}\right) + \left(\frac{4,995}{45.8}\right)} = 45.8 \text{ mi/h}$$

Step 8: Determine LOS

The average density in this two-sided weaving segment is estimated by using Equation 13-23:

$$D = \frac{(v/N)}{S} = \frac{(5,384/3)}{45.8} = 39.2 \text{ pc/mi/ln}$$

From Equation 13-12, this density is clearly in LOS E. It is not far from the 43 pc/h/ln that would likely cause a breakdown.

Discussion

This two-sided weaving segment operates at LOS E, not far from the LOS E/F boundary. The v/c ratio is $4,150/4,573 = 0.91$. The major problem is that 300 veh/h crossing the freeway from ramp to ramp creates a great deal of turbulence in the traffic stream and limits capacity. The speeds estimated for weaving and nonweaving vehicles are effectively the same in this example. Two-sided weaving segments do not operate well with such large numbers of ramp-to-ramp vehicles. If this were a basic freeway segment, the per lane flow rate of $5,405/3 = 1,802$ pc/h/ln would not be considered excessive and would be well within a basic freeway segment's capacity of 2,300 pc/h/ln.

EXAMPLE PROBLEM 4: DESIGN OF A MAJOR WEAVING SEGMENT FOR A DESIRED LOS

The Weaving Segment

A weaving segment is to be designed between two major junctions in which two urban freeways join and then separate, as shown in Exhibit 27-11. The analysis assumes no adverse weather effects or incidents in the segment. Entry and exit legs have the numbers of lanes shown. The maximum length of the weaving segment is 1,000 ft, based on the location of the junctions. The FFS of all entry and exit legs is 75 mi/h. All demands are shown as flow rates under equivalent ideal conditions.

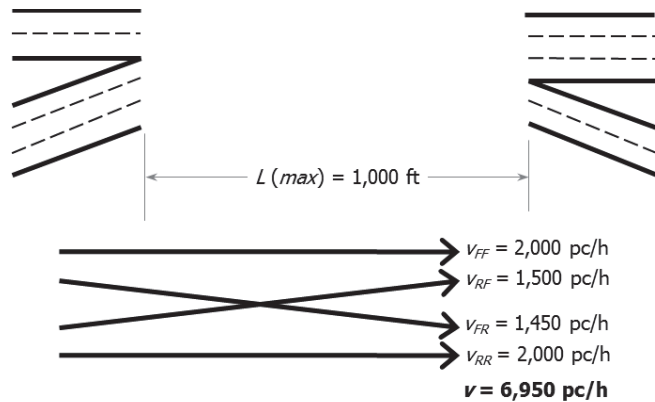

Exhibit 27-11
 Example Problem 4: Major
 Weaving Segment Data

What design would be appropriate to deliver LOS C for the demand flow rates shown?

The Facts

In addition to the information contained in Exhibit 27-11, the following facts are known concerning this weaving segment:

PHF = 1.00 (all demands stated as flow rates),

Heavy vehicles = 0% trucks (all demands in pc/h),

Driver population = regular commuters,

FFS = 75 mi/h (all legs and weaving segment),

$c_{IFL} = 2,400$ pc/h/ln (for FFS = 75 mi/h),

ID = 1 int/mi, and

Terrain = level.

Comments

As is the case in any weaving segment design, considerable constraints are imposed. The problem states that the maximum length is 1,000 ft, no doubt limited by locational issues for the merge and diverge junctions. Shorter lengths are probably not worth investigating, and the maximum should be assumed for all trial designs. The simplest design merely connects entering lanes with exit lanes in a straightforward manner, producing a section of five lanes. A section with four lanes could be considered by merging two lanes into one at the entry gore and separating it into two again at the exit gore. In any event, the design is limited to a section of four or five lanes. No other widths would work without major additions to input and output legs. The configuration cannot be changed without adding a lane to at least one of the entry or exit legs. Thus, the initial trial will be at a length of 1,000 ft, with the five entry lanes connected directly to the five exit lanes, with no changes to the exit or entry leg designs. If this does not produce an acceptable operation, changes will be considered.

While the problem clearly states that all legs are freeways, no feasible configuration produces a two-sided weaving section. Thus, to fit within the one-sided analysis methodology, the right-side entry and exit legs will be classified as ramps in the computational analysis. Note that by inspection, the capacity of all

entry and exit legs is more than sufficient to handle the demand flow rates indicated.

Step 1: Input Data—Trial 1

All input information is given in Exhibit 27-11 and in the accompanying Facts section for this example problem.

Step 2: Adjust Volume—Trial 1

All demands are already stated as flow rates in passenger cars per hour under equivalent ideal conditions. No further adjustments are needed. Critical demand values are as follows:

$$\begin{aligned}
 v_{FF} &= 2,000 \text{ pc/h} \\
 v_{FR} &= 1,450 \text{ pc/h} \\
 v_{RF} &= 1,500 \text{ pc/h} \\
 v_{RR} &= 2,000 \text{ pc/h} \\
 v_W &= 1,500 + 1,450 = 2,950 \text{ pc/h} \\
 v_{NW} &= 2,000 + 2,000 = 4,000 \text{ pc/h} \\
 v &= 2,950 + 4,000 = 6,950 \text{ pc/h} \\
 VR &= 2,950/6,950 = 0.424
 \end{aligned}$$

Step 3: Determine Configuration Characteristics—Trial 1

Exhibit 27-12 illustrates the weaving segment formed under the assumed design discussed previously.

Exhibit 27-12
Example Problem 4: Trial Design 1

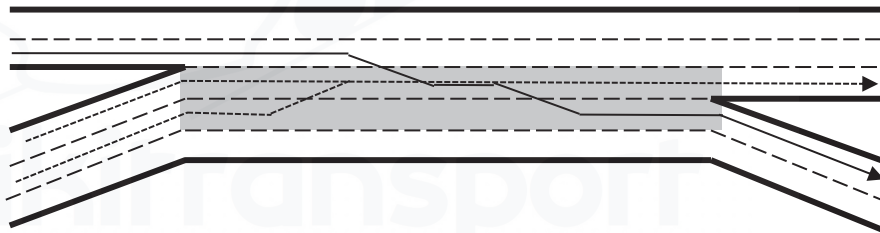

The direct connection of entry and exit legs produces a weaving segment in which the ramp-to-freeway movement can be made without a lane change ($LC_{RF} = 0$). However, freeway-to-ramp vehicles must make two lane changes ($LC_{FR} = 2$). With regard to the lane-changing pattern, there are no lanes on the entering freeway leg from which a weaving maneuver can be made with one or no lane changes. However, ramp drivers wishing to weave can enter on either of the two left ramp lanes and weave with one or no lane changes. Thus, $N_{WL} = 2$.

By using Equation 13-2, LC_{MIN} is computed as

$$\begin{aligned}
 LC_{MIN} &= (LC_{RF} \times v_{RF}) + (LC_{FR} \times v_{FR}) \\
 LC_{MIN} &= (0 \times 1,500) + (2 \times 1,450) = 2,900 \text{ lc/h}
 \end{aligned}$$

Step 4: Determine Maximum Weaving Length—Trial 1

The maximum length of a weaving segment for this configuration and demand scenario is estimated by using Equation 13-4:

$$L_{MAX} = [5,728(1 + VR)^{1.6}] - (1,566N_{WL})$$

$$L_{MAX} = [5,728(1 + 0.424)^{1.6}] - (1,566 \times 2) = 6,950 \text{ ft} > 1,000 \text{ ft}$$

Since the maximum length is much greater than the actual length of 1,000 ft, analysis of the segment with this chapter's methodology is appropriate.

Step 5: Determine Weaving Segment Capacity—Trial 1

The capacity of the weaving segment is controlled by one of two limiting factors: density reaches 43 pc/mi/ln or weaving demand reaches 2,400 pc/h for the configuration of Exhibit 27-12.

Capacity Limited by Density

The capacity limited by reaching a density of 43 pc/mi/ln is estimated by using Equation 13-5 and Equation 13-6:

$$c_{IWL} = c_{IFL} - [438.2(1 + VR)^{1.6}] + (0.0765L_S) + (119.8N_{WL})$$

$$c_{IWL} = 2,400 - [438.2(1 + 0.424)^{1.6}] + (0.0765 \times 1,000) + (119.8 \times 2)$$

$$c_{IWL} = 1,944 \text{ pc/h/ln}$$

$$c_W = c_{IWL} \times N \times f_{HV}$$

$$c_W = 1,944 \times 5 \times 1 = 9,721 \text{ pc/h}$$

Capacity Limited by Weaving Demand Flow

The capacity limited by the weaving demand flow is estimated by using Equation 13-7 and Equation 13-8:

$$c_{IW} = \frac{2,400}{VR} = \frac{2,400}{0.424} = 5,654 \text{ pc/h}$$

$$c_W = c_{IW} \times f_{HV} = 5,654 \times 1 = 5,654 \text{ pc/h}$$

In this case, the capacity of the segment is limited by the maximum weaving flow rate, which limits total capacity of the segment to 5,654 pc/h, which is smaller than the total demand flow rate of 6,950 pc/h. Thus, this section is expected to operate at LOS F. No further analysis is possible with this methodology.

Discussion: Trial 1

This weaving segment would be expected to fail under the proposed design. The critical feature appears to be the configuration. Note that the capacity is limited by the maximum weaving flows that can be sustained, not by a density expected to produce queuing. This is primarily due to the freeway-to-ramp flow, which must make two lane changes. The number of lane changes can be reduced to one by adding one lane to the "ramp" at the exit gore area. This not only reduces the number of lane changes made by 1,450 freeway-to-ramp vehicles but also increases the value of N_W from 2 to 3. In turn, the segment's capacity (as limited by weaving flow rate) is effectively increased to $3,500/VR = 3,500/0.424 =$

8,255 pc/h, which is well in excess of the demand flow rate of 6,950 pc/h. Another analysis (Trial 2) will be conducted by using this approach.

Steps 1 and 2: Input Data and Adjust Volume—Trial 2

Steps 1 and 2 are the same as for Trial 1. They are not repeated here. The new configuration affects the results beginning with Step 3.

Step 3: Determine Configuration Characteristics—Trial 2

Exhibit 27-13 illustrates the new configuration that will result from the changes discussed above. The addition of a lane to the exit-ramp leg allows the freeway-to-ramp movement to be completed with only one lane change ($LC_{FR} = 1$). The value of LC_{RF} is not affected and remains 0. The right lane of the freeway-entry leg can also be used by freeway-to-ramp drivers to make a weaving maneuver with a single lane change, increasing N_{WL} to 3.

Exhibit 27-13
Example Problem 4:
Trial Design 2

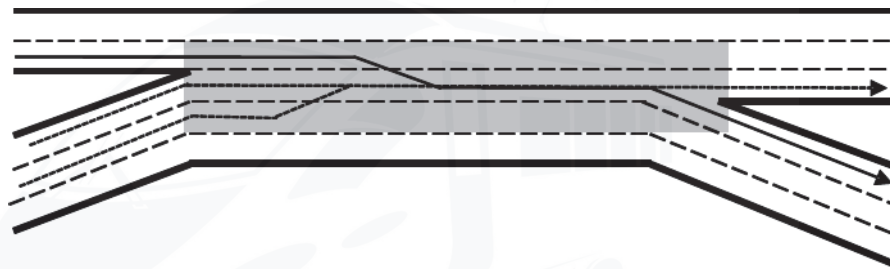

Then

$$LC_{MIN} = (LC_{RF} \times v_{RF}) + (LC_{FR} \times v_{FR})$$

$$LC_{MIN} = (0 \times 1,500) + (1 \times 1,450) = 1,450 \text{ lc/h}$$

Step 4: Determine Maximum Weaving Length—Trial 2

The maximum length of a weaving segment for this configuration and demand scenario is estimated by using Equation 13-4:

$$L_{MAX} = [5,728(1 + VR)^{1.6}] - (1,566N_{WL})$$

$$L_{MAX} = [5,728(1 + 0.424)^{1.6}] - (1,566 \times 3) = 5,391 \text{ ft} > 1,000 \text{ ft}$$

Since the maximum length is much greater than the actual length of 1,000 ft, analyzing the segment by using this chapter’s methodology is appropriate.

Step 5: Determine Weaving Segment Capacity—Trial 2

The capacity of the weaving segment is controlled by one of two limiting factors: density reaches 43 pc/mi/ln or weaving demand reaches 3,500 pc/h for the configuration of Exhibit 27-13.

Capacity Limited by Density

The capacity limited by reaching a density of 43 pc/mi/ln is estimated by using Equation 13-5 and Equation 13-6:

$$c_{IWL} = c_{IFL} - [438.2(1 + VR)^{1.6}] + (0.0765L_S) + (119.8N_{WL})$$

$$c_{IWL} = 2,400 - [438.2(1 + 0.424)^{1.6}] + (0.0765 \times 1,000) + (119.8 \times 3)$$

$$c_{IWL} = 2,064 \text{ pc/h/ln}$$

$$c_W = c_{IWL} \times N \times f_{HV}$$

$$c_W = 2,064 \times 5 \times 1 = 10,320 \text{ pc/h}$$

Capacity Limited by Weaving Demand Flow

The capacity limited by the weaving demand flow is estimated by using Equation 13-7 and Equation 13-8:

$$c_{IW} = \frac{3,500}{VR} = \frac{3,500}{0.424} = 8,255 \text{ pc/h}$$

$$c_W = c_{IW} \times f_{HV} \times f_p = 8,255 \times 1 \times 1 = 8,255 \text{ pc/h}$$

Once again, the capacity of the segment is limited by the maximum weaving flow rate: the difference is that now the capacity is 8,255 pc/h. This is larger than the total demand flow rate of 6,950 pc/h. Thus, this section is expected to operate without breakdown, and the analysis may continue.

Step 6: Determine Lane-Changing Rates—Trial 2

Equation 13-11 through Equation 13-17 are used to estimate the lane-changing rates of weaving and nonweaving vehicles in the weaving segment. In turn, these will be used to estimate weaving and nonweaving vehicle speeds.

Weaving Vehicle Lane-Changing Rate

$$LC_W = LC_{MIN} + 0.39[(L_S - 300)^{0.5} N^2 (1 + ID)^{0.8}]$$

$$LC_W = 1,450 + 0.39[(1,000 - 300)^{0.5} (5^2)(1 + 1)^{0.8}] = 1,899 \text{ lc/h}$$

Nonweaving Vehicle Lane-Changing Rate

$$I_{NW} = \frac{L_S \times ID \times v_{NW}}{10,000}$$

$$I_{NW} = \frac{1,000 \times 1 \times 4,000}{10,000} = 400 < 1,300$$

$$LC_{NW} = (0.206v_{NW}) + (0.542L_S) - (192.6N)$$

$$LC_{NW} = (0.206 \times 4,000) + (0.542 \times 1,000) - (192.6 \times 5) = 403 \text{ lc/h}$$

Total Lane-Changing Rate

$$LC_{ALL} = LC_W + LC_{NW} = 1,899 + 403 = 2,302 \text{ lc/h}$$

Step 7: Determine Average Speeds of Weaving and Nonweaving Vehicles—Trial 2

The average speeds of weaving and nonweaving vehicles are computed from Equation 13-18 through Equation 13-21.

$$W = 0.226 \left(\frac{LC_{ALL}}{L_S} \right)^{0.789}$$

$$W = 0.226 \left(\frac{2,302}{1,000} \right)^{0.789} = 0.436$$

Then

$$S_W = 15 + \left(\frac{FFS \times SAF - 15}{1 + W} \right)$$

$$S_W = 15 + \left(\frac{75 \times 1 - 15}{1 + 0.436} \right) = 56.8 \text{ mi/h}$$

and

$$S_{NW} = FFS \times SAF - (0.0072LC_{MIN}) - \left(0.0048 \frac{v}{N} \right)$$

$$S_{NW} = 75 \times 1 - (0.0072 \times 1,450) - \left(0.0048 \frac{6,950}{5} \right) = 57.9 \text{ mi/h}$$

Equation 13-22 is now used to compute the average speed of all vehicles in the segment:

$$S = \frac{v_W + v_{NW}}{\left(\frac{v_W}{S_W} \right) + \left(\frac{v_{NW}}{S_{NW}} \right)}$$

$$S = \frac{4,000 + 2,950}{\left(\frac{4,000}{57.9} \right) + \left(\frac{2,950}{56.8} \right)} = 57.4 \text{ mi/h}$$

Step 8: Determine the Level of Service—Trial 2

The average density in the weaving segment is estimated by using Equation 13-23:

$$D = \frac{(v/N)}{S} = \frac{(6,950/5)}{57.4} = 24.2 \text{ pc/mi/ln}$$

From Exhibit 13-12, this density is within the stated boundaries of LOS C (20 to 28 pc/mi/ln). Since the design target was LOS C, the second trial design is acceptable.

Discussion: Trial 2

The relatively small change in the configuration makes all the difference in this design. LOS C can be achieved by adding a lane to the right exit leg; without it, the section fails because of excessive weaving turbulence. If the extra lane is not needed on the departing freeway leg, it will be dropped somewhere downstream, perhaps as part of the next interchange. The extra lane would have to be carried for several thousand feet to be effective. An added lane generally will not be fully utilized by drivers if they are aware that it will be immediately dropped.

EXAMPLE PROBLEM 5: CONSTRUCTING A SERVICE VOLUME TABLE FOR A WEAVING SEGMENT

This example shows how a table of service flow rates or service volumes or both can be constructed for a weaving section with certain specified characteristics. The methodology of this chapter does not directly yield service flow rates or service volumes, but they can be developed by using spreadsheets or more sophisticated computer programs.

The key issue is the definition of the threshold values for the various levels of service. For weaving sections on freeways, levels of service are defined as limiting densities, as shown in Exhibit 27-14:

LOS	Maximum Density (pc/mi/ln)
A	10
B	20
C	28
D	35

Exhibit 27-14
Example Problem 5: Maximum Density Thresholds for LOS A–D

By definition, the service flow rate at LOS E is the capacity of the weaving section, which may or may not be keyed to a density.

Before the construction of such a table is illustrated, several key definitions should be reviewed:

- *Service flow rate (under ideal conditions)*: The maximum rate of flow under equivalent ideal conditions that can be sustained while maintaining the designated LOS (*SFI*, pc/h).
- *Service flow rate (under prevailing conditions)*: The maximum rate of flow under prevailing conditions that can be sustained while maintaining the designated LOS (*SF*, veh/h).
- *Service volume*: The maximum hourly volume under prevailing conditions that can be sustained while maintaining the designated LOS in the worst 15 min of the hour (*SV*, veh/h).
- *Daily service volume*: The maximum annual average daily traffic under prevailing conditions that can be sustained while maintaining the designated LOS in the worst 15 min of the peak hour (*DSV*, veh/day).

Note that flow rates are for a 15-min period, often a peak 15 min within the analysis hour, or the peak hour. These values are related as follows:

$$SF_i = SFI_i \times f_{HV}$$

$$SV_i = SF_i \times PHF$$

$$DSV_i = \frac{SV_i}{K \times D}$$

This chapter's methodology estimates both the capacity and the density expected in a weaving segment of given geometric and demand characteristics. Conceptually, the approach to generating values of *SFI* is straightforward: for any given situation, keep increasing the input flow rates until the boundary density for the LOS is reached; the input flow rate is the *SFI* for that situation and LOS. This obviously involves many iterations. A spreadsheet can be programmed to do this, either semiautomatically with manual input of demands, or fully automatically, with the spreadsheet automatically generating solutions until a density match is found. The latter method is not very efficient and involves a typical spreadsheet program running for several hours. A program could, of course, be written to automate the entire process.

An Example

While all of the computations cannot be shown, demonstration results for a specific case can be illustrated. A service volume table is desired for a weaving section with the following characteristics:

- One-sided major weaving section
- Demand splits as follows:
 - $v_{FF} = 65\%$ of v
 - $v_{RF} = 15\%$ of v
 - $v_{FR} = 12\%$ of v
 - $v_{RR} = 8\%$ of v
- Trucks = 5%
- Level terrain
- PHF = 0.93
- Regular commuters in the traffic stream
- $ID = 1$ interchange/mi
- FFS = 65 mi/h

For these characteristics, a service volume table can be constructed for a range of lengths and widths and for configurations in which N_w is 2 and 3. For illustrative purposes, lengths of 500, 1,000, 1,500, 2,000, and 2,500 ft and widths of three, four, or five lanes will be used. In a major weaving section, one weaving flow does not have to make a lane change. In this example, the ramp-to-freeway movement is assumed to have this characteristic. The freeway-to-ramp movement would require one or two lane changes, on the basis of the value of N_{WL} .

First Computations

Initial computations will be aimed at establishing values of SFI for the situations described. A spreadsheet will be constructed in which the first column is the flow rate to be tested (in passenger cars per hour under ideal conditions), and the last column produces a density. Each line will be iterated (manually in this case) until each threshold density value is reached. Intermediate columns will be programmed to produce the intermediate results needed to get to this result. Because maximum length and capacity are decided at intermediate points, the applicable results will be manually entered before continuing. Such a procedure is less difficult than it seems once the basic computations are programmed. Manual iteration using the input flow rate is efficient; the operator will observe how fast the results are converging to the desired threshold and will change the inputs accordingly.

The results of a first computation are shown in Exhibit 27-15. They represent service flow rates under ideal conditions, SFI . Consistent with the HCM's results presentation guidelines (Chapter 7, Interpreting HCM and Alternative Tool Results), all hourly service flow rates and volumes in these exhibits have been rounded down to the nearest 100 passenger cars or vehicles for presentation.

LOS	Length of Weaving Section (ft)													
	500	1,000	1,500	2,000	2,500	500	1,000	1,500	2,000	2,500				
<i>N</i> = 3; <i>N_{WL}</i> = 2					<i>N</i> = 3; <i>N_{WL}</i> = 3									
A	1,700	1,700	1,700	1,700	1,700	1,800	1,800	1,800	1,800	1,800	1,800	1,800	1,800	1,800
B	3,200	3,200	3,200	3,200	3,200	3,300	3,300	3,400	3,400	3,400	3,400	3,400	3,400	3,400
C	4,200	4,200	4,300	4,300	4,300	4,400	4,500	4,500	4,500	4,500	4,500	4,500	4,500	4,500
D	5,000	5,100	5,100	5,100	5,100	5,300	5,400	5,400	5,500	5,500	5,500	5,500	5,500	5,500
E	5,900	6,000	6,100	6,300	6,400	6,300	6,400	6,500	6,600	6,600	6,600	6,600	6,700	6,700
<i>N</i> = 4; <i>N_{WL}</i> = 2					<i>N</i> = 4; <i>N_{WL}</i> = 3									
A	2,200	2,300	2,300	2,300	2,300	2,300	2,300	2,300	2,300	2,300	2,300	2,300	2,300	2,300
B	4,100	4,200	4,200	4,200	4,200	4,300	4,400	4,400	4,400	4,400	4,400	4,400	4,400	4,400
C	5,400	5,500	5,500	5,500	5,600	5,800	5,900	5,900	5,900	5,900	5,900	5,900	5,900	5,900
D	6,300	6,500	6,500	6,600	6,600	6,900	7,000	7,100	7,100	7,100	7,100	7,100	7,100	7,100
E	7,900	8,000	8,200	8,400	8,500	8,400	8,500	8,700	8,800	8,800	8,800	8,800	9,000	9,000
<i>N</i> = 5; <i>N_{WL}</i> = 2					<i>N</i> = 5; <i>N_{WL}</i> = 3									
A	2,800	2,800	2,800	2,800	2,800	2,900	2,900	2,900	2,900	2,900	2,900	2,900	2,900	2,900
B	5,000	5,100	5,100	5,100	5,100	5,400	5,400	5,400	5,500	5,500	5,500	5,500	5,500	5,500
C	6,500	6,600	6,700	6,700	6,700	7,100	7,200	7,200	7,300	7,300	7,300	7,300	7,300	7,300
D	7,600	7,800	7,900	7,900	7,900	8,400	8,600	8,700	8,700	8,700	8,700	8,700	8,700	8,700
E	8,800	8,800	8,800	8,800	8,800	10,500	10,700	10,900	11,100	11,100	11,100	11,100	11,200	11,200

Exhibit 27-15

Example Problem 5: Service Flow Rates (pc/h) Under Ideal Conditions (*SF*)

Exhibit 27-16 shows service flow rates under prevailing conditions, *SF*. Each value in Exhibit 27-15 (before rounding) is multiplied by

$$f_{HV} = \frac{1}{1 + P_T(E_T - 1)} = \frac{1}{1 + 0.05(2 - 1)} = 0.952$$

LOS	Length of Weaving Section (ft)													
	500	1,000	1,500	2,000	2,500	500	1,000	1,500	2,000	2,500				
<i>N</i> = 3; <i>N_{WL}</i> = 2					<i>N</i> = 3; <i>N_{WL}</i> = 3									
A	1,600	1,600	1,600	1,600	1,600	1,700	1,700	1,700	1,700	1,700	1,700	1,700	1,700	1,700
B	3,000	3,000	3,100	3,100	3,100	3,100	3,200	3,200	3,200	3,200	3,200	3,200	3,200	3,200
C	4,000	4,000	4,100	4,100	4,100	4,200	4,300	4,300	4,300	4,300	4,300	4,300	4,300	4,300
D	4,700	4,800	4,900	4,900	4,900	5,100	5,100	5,200	5,200	5,200	5,200	5,200	5,200	5,200
E	5,600	5,700	5,800	5,900	6,100	6,000	6,100	6,200	6,200	6,200	6,200	6,200	6,400	6,400
<i>N</i> = 4; <i>N_{WL}</i> = 2					<i>N</i> = 4; <i>N_{WL}</i> = 3									
A	2,100	2,100	2,200	2,200	2,200	2,200	2,200	2,200	2,200	2,200	2,200	2,200	2,200	2,200
B	3,900	4,000	4,000	4,000	4,000	4,100	4,200	4,200	4,200	4,200	4,200	4,200	4,200	4,200
C	5,100	5,200	5,200	5,300	5,300	5,500	5,600	5,600	5,600	5,600	5,600	5,600	5,600	5,600
D	5,900	6,200	6,200	6,300	6,300	6,600	6,700	6,700	6,800	6,800	6,800	6,800	6,800	6,800
E	7,500	7,700	7,800	7,900	8,100	8,000	8,100	8,200	8,400	8,400	8,400	8,400	8,500	8,500
<i>N</i> = 5; <i>N_{WL}</i> = 2					<i>N</i> = 5; <i>N_{WL}</i> = 3									
A	2,600	2,700	2,700	2,700	2,700	2,700	2,700	2,800	2,800	2,800	2,800	2,800	2,800	2,800
B	4,700	4,800	4,900	4,900	4,900	5,100	5,100	5,200	5,200	5,200	5,200	5,200	5,200	5,200
C	6,200	6,300	6,300	6,400	6,400	6,700	6,800	6,900	6,900	6,900	6,900	6,900	6,900	6,900
D	7,300	7,400	7,500	7,500	7,500	8,000	8,200	8,200	8,300	8,300	8,300	8,300	8,300	8,300
E	8,400	8,400	8,400	8,400	8,400	10,000	10,200	10,300	10,500	10,500	10,500	10,500	10,700	10,700

Exhibit 27-16

Example Problem 5: Service Flow Rates (veh/h) Under Prevailing Conditions (*SF*)

Exhibit 27-17 shows service volumes, *SV*. Each value in Exhibit 27-16 (before rounding) is multiplied by a PHF of 0.93.

Exhibit 27-17

Example Problem 5: Service Volumes (veh/h) Under Prevailing Conditions (SV)

LOS	Length of Weaving Section (ft)									
	500	1,000	1,500	2,000	2,500	500	1,000	1,500	2,000	2,500
<i>N</i> = 3; <i>N_{WL}</i> = 2					<i>N</i> = 3; <i>N_{WL}</i> = 3					
A	1,500	1,500	1,500	1,500	1,500	1,500	1,500	1,500	1,500	1,500
B	2,800	2,800	2,800	2,800	2,900	2,900	2,900	3,000	3,000	3,000
C	3,700	3,700	3,800	3,800	3,800	3,900	4,000	4,000	4,000	4,000
D	4,400	4,500	4,500	4,500	4,500	4,700	4,800	4,800	4,800	4,800
E	5,200	5,300	5,400	5,500	5,600	5,500	5,600	5,700	5,800	5,900
<i>N</i> = 4; <i>N_{WL}</i> = 2					<i>N</i> = 4; <i>N_{WL}</i> = 3					
A	2,000	2,000	2,000	2,000	2,000	2,000	2,100	2,100	2,100	2,100
B	3,600	3,700	3,700	3,700	3,700	3,800	3,900	3,900	3,900	3,900
C	4,700	4,800	4,900	4,900	4,900	5,100	5,200	5,200	5,200	5,200
D	5,500	5,700	5,800	5,800	5,800	6,100	6,200	6,300	6,300	6,300
E	7,000	7,100	7,300	7,400	7,500	7,400	7,500	7,700	7,800	7,900
<i>N</i> = 5; <i>N_{WL}</i> = 2					<i>N</i> = 5; <i>N_{WL}</i> = 3					
A	2,400	2,500	2,500	2,500	2,500	2,500	2,500	2,600	2,600	2,600
B	4,400	4,500	4,500	4,500	4,500	4,700	4,800	4,800	4,800	4,800
C	5,700	5,800	5,900	5,900	5,900	6,200	6,400	6,400	6,400	6,400
D	6,700	6,900	7,000	7,000	7,000	7,500	7,600	7,700	7,700	7,700
E	7,800	7,800	7,800	7,800	7,800	9,300	9,400	9,600	9,800	9,900

Exhibit 27-18 shows daily service volumes, *DSV*. An illustrative *K*-factor of 0.08 (typical of a large urban area) and an illustrative *D*-factor of 0.55 (typical of an urban route without strong peaking by direction) are used. Each nonrounded value used to generate Exhibit 27-17 was divided by both of these numbers.

Exhibit 27-18

Example Problem 5: Daily Service Volumes (veh/day) Under Prevailing Conditions (*DSV*)

LOS	Length of Weaving Section (ft)									
	500	1,000	1,500	2,000	2,500	500	1,000	1,500	2,000	2,500
<i>N</i> = 3; <i>N_{WL}</i> = 2					<i>N</i> = 3; <i>N_{WL}</i> = 3					
A	35,200	35,200	35,400	35,500	35,600	36,200	36,300	36,300	36,300	36,300
B	64,300	65,300	65,500	65,700	66,100	67,600	68,000	68,400	68,400	68,400
C	84,700	86,100	86,700	87,200	87,500	89,700	90,900	91,500	91,700	91,900
D	100,800	102,800	103,600	104,000	104,400	107,800	109,600	110,200	110,600	110,800
E	119,800	122,100	124,400	126,700	129,100	127,000	129,400	131,600	132,800	136,300
<i>N</i> = 4; <i>N_{WL}</i> = 2					<i>N</i> = 4; <i>N_{WL}</i> = 3					
A	45,800	46,200	46,600	46,600	46,600	47,600	47,800	47,800	47,900	47,900
B	83,300	84,700	85,100	85,500	85,700	88,300	89,300	89,500	89,700	89,900
C	108,600	110,800	111,600	112,200	112,600	117,100	118,700	119,500	120,100	120,300
D	126,700	131,300	132,400	133,200	133,600	140,000	142,400	143,600	144,000	144,400
E	159,800	162,800	165,900	169,000	172,100	169,400	172,500	175,400	178,600	181,700
<i>N</i> = 5; <i>N_{WL}</i> = 2					<i>N</i> = 5; <i>N_{WL}</i> = 3					
A	56,300	57,100	57,300	57,500	57,500	58,700	58,900	59,300	59,400	59,400
B	101,400	103,000	103,600	104,200	104,400	108,600	109,600	110,000	110,600	110,800
C	131,300	133,800	135,000	135,800	136,200	142,800	145,400	146,200	146,800	147,400
D	154,500	157,700	159,100	159,900	160,300	170,600	173,600	175,000	175,800	175,800
E	178,800	178,800	178,800	178,800	178,800	211,800	215,600	219,500	223,300	227,200

This example problem illustrates how service volume tables may be created for a given set of weaving parameters. So many variables affect the operation of a weaving segment that “typical” service volume tables are not recommended. They may be significantly misleading when they are applied to segments with different parameters.

EXAMPLE PROBLEM 6: LOS OF AN ML ACCESS SEGMENT WITH CROSS-WEAVING

The ML Access Segment

Exhibit 27-19 shows a freeway facility that includes both general purpose and managed lanes. The analysis assumes no adverse weather effects or incidents in the segment. A freeway with an adjacent managed lane facility is evaluated as two parallel lane groups, as discussed in more detail in Chapter 10, Freeway Facilities Core Methodology. The example below shows two segments, each with two adjacent lane groups. Lane Group Pair 1 in the first segment includes a general purpose (GP) merge segment and a managed lane (ML) basic segment. Lane Group Pair 2 consists of GP and ML access segments.

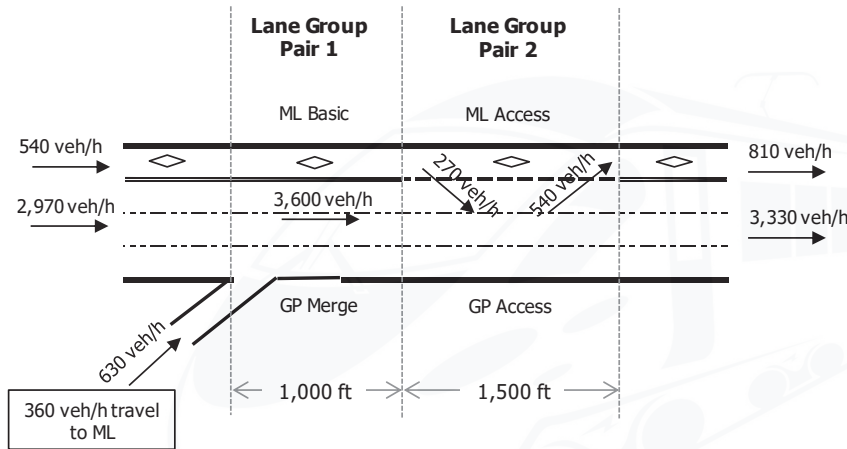

Note: GP = general purpose, ML = managed lane.

What is the capacity reduction in the GP merge segment due to cross-weaving, and what is the expected LOS for the ML access segment with the demand flow rates shown?

The Facts

In addition to the information given in Exhibit 27-19, the following facts are known about the subject weaving segment:

PHF = 0.90;

Heavy vehicles = 0% single-unit trucks, 0% tractor-trailer;

Driver population = regular commuters;

FFS = 65 mi/h (for both managed and general purpose lanes);

c_{FL} = 2,350 pc/h/ln (for FFS = 65 mi/h);

ID = 1.0 interchange/mi; and

Terrain = level.

Comments

Lane-changing characteristics will be estimated for Lane Group Pair 2. The maximum length for weaving operations in the access segments will be

Exhibit 27-19
Example Problem 6:
ML Access Segment with
Cross-Weaving

estimated and compared with the segment's actual length. The access segment's capacity will be estimated and compared with demand to determine whether LOS F exists. If it does not, component flow speeds will be estimated and averaged. Finally, the access segment density will be estimated and Exhibit 13-6 used to determine the expected LOS.

Capacity Reduction in GP Merge Segment (Lane Group Pair 1)

The capacity reduction due to the cross-weave effect is evaluated for Lane Group Pair 1. On the basis of the facility configuration provided in Exhibit 27-19, the L_{cw-min} and L_{cw-max} values are 1,000 ft and 2,500 ft, respectively. The cross-weave demand volume is $360/0.9 = 400$ veh/h. The number of general purpose lanes N_{GP} is 3. Thus the capacity reduction factor CRF will be

$$CRF = -0.0897 + 0.0252 \ln(CW) - 0.00001453L_{cw-min} + 0.002967N_{GP}$$

$$CRF = 0.056$$

Performance of ML Access Segment (Lane Group Pair 2)

The following steps illustrate the computations in the ML access segment, which is described above as Lane Group Pair 2.

Step 1: Input Data

All input data are stated in Exhibit 27-19 and the Facts section.

Step 2: Adjust Volume

The flow rates are computed on the basis of the hourly demand flow rates by using the specified PHF.

$$v_{FF} = \frac{3,060}{0.9} = 3,400 \text{ pc/h}$$

$$v_{FR} = \frac{540}{0.9} = 600 \text{ pc/h}$$

$$v_{RF} = \frac{270}{0.9} = 300 \text{ pc/h}$$

$$v_{RR} = \frac{270}{0.9} = 300 \text{ pc/h}$$

$$v_W = 600 + 300 = 900 \text{ pc/h}$$

$$v_{NW} = 3,400 + 300 = 3,700 \text{ pc/h}$$

$$v = 3,700 + 900 = 4,600 \text{ pc/h}$$

$$VR = \frac{900}{4,600} = 0.196$$

Exhibit 27-20 summarizes the hourly flow rates computed on the basis of hourly demand flow rates.

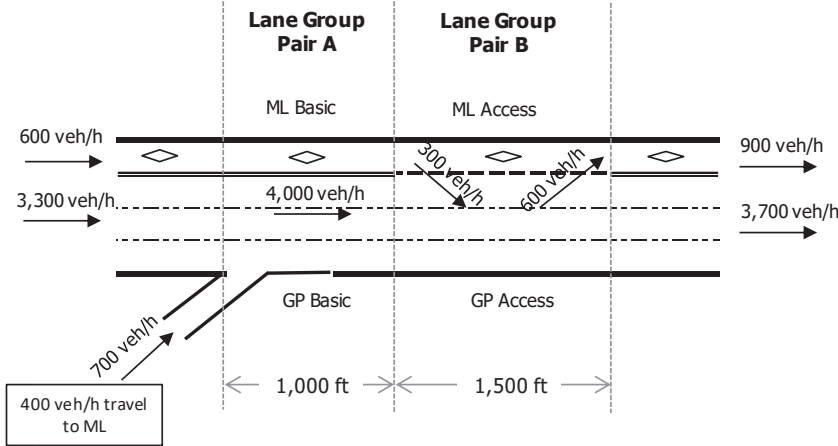

Note: GP = general purpose, ML = managed lane.

Step 3: Determine Configuration Characteristics

The configuration of the ML access segment is examined to determine the values of LC_{RF} , LC_{FR} and N_{WL} . The lane geometry is illustrated in Exhibit 27-21. From these values, the minimum number of lane changes by weaving vehicles LC_{MIN} is computed.

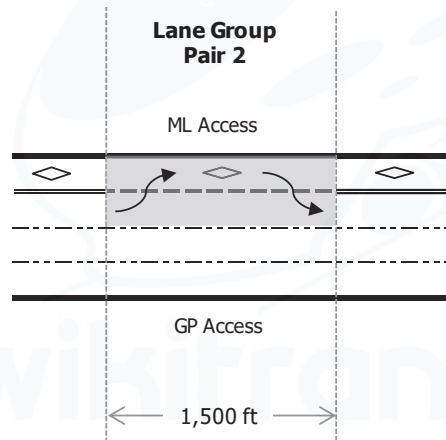

Note: GP = general purpose, ML = managed lane.

From Exhibit 27-21, it is clear that all ramp-to-freeway vehicles must make at least one lane change ($LC_{RF} = 1$). Similarly, all freeway-to-ramp vehicles must make at least one lane change ($LC_{FR} = 1$). In addition, a weaving maneuver can only be completed with a single lane change from the leftmost lane of the freeway or the auxiliary lane ($N_{WL} = 2$). Then, by using Equation 13-2, LC_{MIN} is computed as

$$LC_{MIN} = (LC_{RF} \times v_{RF}) + (LC_{FR} \times v_{FR})$$

$$LC_{MIN} = (1 \times 300) + (1 \times 600) = 900 \text{ lc/h}$$

Step 4: Determine Maximum Weaving Length

The maximum length over which weaving operations may exist for the segment described is found by using Equation 13-4:

Exhibit 27-20
Example Problem 6: Hourly Flow Rates After PHF Is Applied

Exhibit 27-21
Example Problem 6: Configuration Characteristics

$$L_{MAX} = [5,728(1 + VR)^{1.6}] - (1,566N_{WL})$$

$$L_{MAX} = [5,728(1 + 0.196)^{1.6}] - (1,566 \times 2) = 4,495 \text{ ft} > 1,500 \text{ ft}$$

Because the maximum length for weaving operations significantly exceeds the actual length, the segment qualifies as a weaving segment, and the analysis continues.

Step 5: Determine Weaving Segment Capacity

The capacity of the weaving segment is controlled by one of two limiting factors: density reaching 43 pc/mi/ln or weaving demand reaching 2,350 pc/h for the configuration of Exhibit 27-19 (a ramp-weave with $N_{WL} = 2$).

Capacity Limited by Density

The capacity limited by reaching a density of 43 pc/mi/ln is estimated by using Equation 13-5 and Equation 13-6:

$$c_{IWL} = c_{IFL} - [438.2(1 + VR)^{1.6}] + (0.0765L_S) + (119.8N_{WL})$$

$$c_{IWL} = 2,350 - [438.2(1 + 0.196)^{1.6}] + (0.0765 \times 1,500) + (119.8 \times 2)$$

$$c_{IWL} = 2,121 \text{ pc/h/ln}$$

$$c_W = c_{IWL} \times N \times f_{HV}$$

$$c_W = 2,121 \times 4 \times 1 = 8,483 \text{ pc/h}$$

Capacity Limited by Weaving Demand Flow

The capacity limited by the weaving demand flow is estimated by using Equation 13-7 and Equation 13-8:

$$c_{IW} = \frac{2,400}{VR} = \frac{2,400}{0.196} = 12,245 \text{ pc/h}$$

$$c_W = c_{IW} \times f_{HV}$$

$$c_W = 12,245 \times 1 = 12,245 \text{ pc/h}$$

The controlling capacity is the smaller of the two values, or 8,483 pc/h. At this point, the value is usually stated as vehicles per hour. In this case, because inputs were already adjusted and were stated in passenger cars per hour, conversions back to vehicles per hour are not possible.

Since the capacity of the weaving segment is larger than the demand flow rate of 4,600 pc/h, LOS F does not exist, and the analysis may continue.

Capacity of Input and Output Roadways

Although it is rarely a factor in weaving operations, the capacity of input and output roadways should be checked to ensure that no deficiencies exist. There are three input and output freeway lanes (with FFS = 65 mi/h). The capacities of the entry and exit ramps are determined for a basic managed lane segment with a free-flow speed of 65 mi/h, separated by markings. The criteria of Chapter 12 are used to determine the capacity of the freeway legs and the managed lane entry and exit lanes. Demand flows and capacities are compared in Exhibit 27-22.

Leg	Demand Flow (pc/h)	Capacity (pc/h)
Freeway entry	4,000	$3 \times 2,350 = 7,050$
Freeway exit	$4,000 + 300 - 600 = 3,700$	$3 \times 2,350 = 7,050$
Ramp entry	600	1,700
Ramp exit	$600 - 300 + 600 = 900$	1,700

Exhibit 27-22
Example Problem 6: Capacity of Entry and Exit Legs

The capacities of all input and output roadways are sufficient to accommodate the demand flow rates.

Step 6: Determine Lane-Changing Rates

Equation 13-11 through Equation 13-17 are used to estimate the lane-changing rates of weaving and nonweaving vehicles in the access segment. These rates will be used in Step 7 to estimate the weaving and nonweaving vehicle speeds.

Weaving Vehicle Lane-Changing Rate

$$LC_W = LC_{MIN} + 0.39[(L_S - 300)^{0.5} N^2 (1 + ID)^{0.8}]$$

$$LC_W = 900 + 0.39[(1,500 - 300)^{0.5} (4^2) (1 + 1)^{0.8}] = 1,276 \text{ lc/h}$$

Nonweaving Vehicle Lane-Changing Rate

$$I_{NW} = \frac{L_S \times ID \times v_{NW}}{10,000}$$

$$I_{NW} = \frac{1,500 \times 1 \times 3,700}{10,000} = 555 < 1,300$$

$$LC_{NW} = LC_{NW1} = (0.206v_{NW}) + (0.542L_S) - (192.6N)$$

$$LC_{NW} = (0.206 \times 3,700) + (0.542 \times 1,500) - (192.6 \times 4) = 805 \text{ lc/h}$$

Total Lane-Changing Rate

$$LC_{ALL} = LC_W + LC_{NW} = 1,276 + 805 = 2,081 \text{ lc/h}$$

Step 7: Determine Average Speeds of Weaving and Nonweaving Vehicles

The average speeds of weaving and nonweaving vehicles are computed from Equation 13-18 through Equation 13-21:

$$W = 0.226 \left(\frac{LC_{ALL}}{L_S} \right)^{0.789}$$

$$W = 0.226 \left(\frac{2,081}{1,500} \right)^{0.789} = 0.293$$

Then

$$S_W = 15 + \left(\frac{FFS \times SAF - 15}{1 + W} \right)$$

$$S_W = 15 + \left(\frac{65 \times 1 - 15}{1 + 0.293} \right) = 53.7 \text{ mi/h}$$

and

$$S_{NW} = FFS \times SAF - (0.0072LC_{MIN}) - \left(0.0048 \frac{v}{N} \right)$$

$$S_{NW} = 65 \times 1 - (0.0072 \times 900) - \left(0.0048 \frac{4,600}{4}\right) = 53.0 \text{ mi/h}$$

Equation 13-22 is now used to compute the average speed of all vehicles in the segment:

$$S = \frac{v_W + v_{NW}}{\left(\frac{v_W}{S_W}\right) + \left(\frac{v_{NW}}{S_{NW}}\right)}$$

$$S = \frac{900 + 3,700}{\left(\frac{900}{53.7}\right) + \left(\frac{3,700}{53.0}\right)} = 53.1 \text{ mi/h}$$

Step 8: Determine LOS

The average density in the weaving segment is estimated by using Equation 13-23.

$$D = \frac{(v/N)}{S} = \frac{(4,600/4)}{53.1} = 21.7 \text{ pc/mi/ln}$$

From Exhibit 13-6, this density is within the stated boundaries of LOS C (20 to 28 pc/mi/ln).

Discussion

As noted, the access segment is operating at LOS C. Weaving and nonweaving speeds are relatively high, suggesting a nearly stable flow. The demand flow rate of 4,600 pc/h is well below the access segment’s capacity of 8,483 pc/h.

EXAMPLE PROBLEM 7: ML ACCESS SEGMENT WITH DOWNSTREAM OFF-RAMP

An ML access segment is illustrated in Exhibit 27-23. The movements in and out of the managed lane may be considered to be analogous to a ramp-weave segment and analyzed accordingly. The impact of cross-weaving traffic between the managed lane and the nearby off-ramp must also be analyzed to determine its impact on capacity of the general purpose lanes.

Exhibit 27-23
Example Problem 7:
ML Access Segment Data

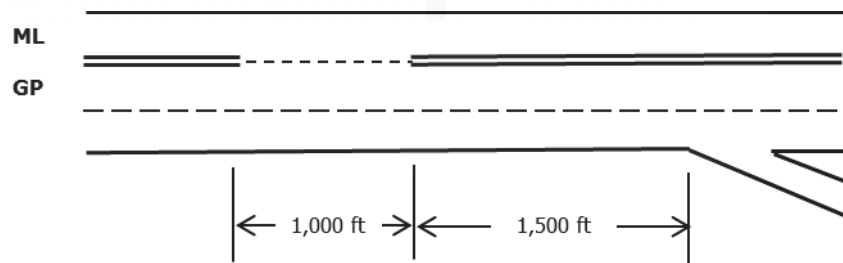

Note: GP = general purpose, ML = managed lane.

The FFS of the segment is 70 mi/h and the interchange density, ID , is 1 interchange per mile. Demand flow rates for this segment are shown in Exhibit 27-24. Note that all demand flows are stated in passenger car equivalents and represent the flow rate in the worst 15-min period of the hour.

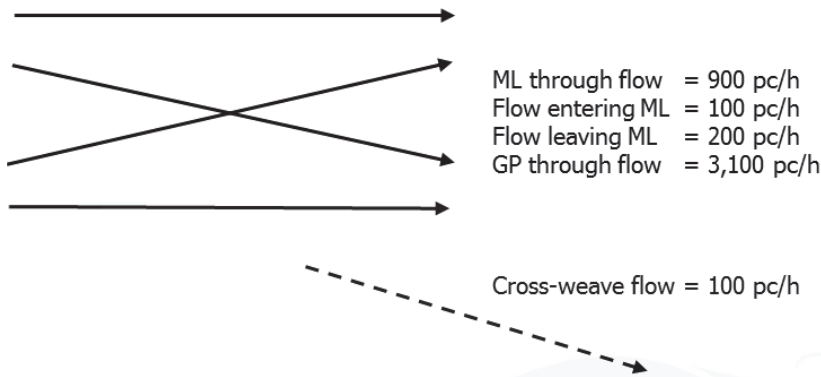

Exhibit 27-24
 Example Problem 7: Weaving
 Flows for Managed Lane
 Segment

Note: GP = general purpose, ML = managed lane.

Part 1: Analysis of the Weaving Between Managed Lanes and General Purpose Lanes

The first major issue to consider is the weaving segment created by movements into and out of the managed lane in the 1,000-ft access segment. This segment is treated as a ramp-weave configuration with a total of three lanes (including the managed lane). This is a bit of an approximation, given that the geometry of the managed lane is better than that of typical ramps in a ramp-weave segment. Speeds of weaving vehicles are likely to be underestimated, since approach speeds on the managed lane are considerably higher than what would be expected on a typical ramp.

Weaving Movements and Parameters

The primary weaving activity is between vehicles entering and leaving the managed lane in the 1,000-ft access segment. This may be treated as a three-lane ramp-weave segment and is analyzed with the basic methodology of this chapter.

Because of the simplicity of this case, certain parameters may be established by inspection:

$$N_{WL} = 2 \text{ lanes,}$$

$$LC_{MIN} = 100 + 200 = 300 \text{ lc/h, and}$$

$$VR = 300 / 4,300 = 0.07.$$

All ramp weaves have two weaving lanes, and each weaving vehicle in a ramp weave must execute one lane change.

Maximum Weaving Length

The maximum weaving length is determined with Equation 13-4.

$$L_{MAX} = [5,728(1 + VR)^{1.6}] - (1,566N_{WL})$$

$$L_{MAX} = [5,728(1 + 0.07)^{1.6}] - (1,566 \times 2) = 3,251 \text{ ft} > 1,000 \text{ ft}$$

The result is significantly longer than the actual weaving length of 1,000 ft. Thus, the access segment may be treated by using the weaving procedure.

Weaving Segment Capacity

The capacity of the ML access segment (a weaving segment) may be based on density limits (43 pc/mi/ln) or on the maximum weaving flow that can be accommodated by the ramp-weave configuration (2,400 pc/h).

The former is estimated by using Equations 13-5 and 13-6.

$$c_{IWL} = c_{IFL} - [438.2(1 + VR)^{1.6}] + (0.0765L_S) + (119.8N_{WL})$$

$$c_{IWL} = 2,400 - [438.2(1 + 0.07)^{1.6}] + (0.0765 \times 1,000) + (119.8 \times 2)$$

$$c_{IWL} = 2,228 \text{ pc/h/ln}$$

$$c_W = c_{IWL} \times N \times f_{HV}$$

$$c_W = 2,228 \times 3 \times 1 = 6,684 \text{ pc/h}$$

The capacity limited by maximum weaving flow is computed by using Equations 13-7 and 13-8.

$$c_{IW} = \frac{2,400}{VR} = \frac{2,400}{0.07} = 34,286 \text{ pc/h}$$

$$c_W = c_{IW} \times f_{HV} = 34,286 \times 1 = 34,286 \text{ pc/h}$$

Obviously, the capacity is controlled by maximum density and is established as 6,684 pc/h. Since the total flow in the segment is $900 + 100 + 200 + 3,100 = 4,300$ pc/h, failure (LOS F) is not expected, and the analysis of the weaving area continues. By inspection and comparison with Chapter 12 criteria, demand does not exceed capacity on any of the entry or exit roadways.

Estimate Lane-Changing Rates

To estimate total lane-changing rates, the total number of lane changes made by weaving and nonweaving vehicles (within the 1,000-ft access segment) must be estimated.

The total lane-changing rate for weaving vehicles is determined by using Equation 13-11.

$$LC_W = LC_{MIN} + 0.39[(L_S - 300)^{0.5} N^2 (1 + ID)^{0.8}]$$

$$LC_W = 300 + 0.39[(1,000 - 300)^{0.5} (3^2) (1 + 1)^{0.8}] = 462 \text{ lc/h}$$

The total lane-changing rate for nonweaving vehicles is found by using Equation 13-13 or 13-14, depending on the value of the nonweaving vehicle index computed with Equation 13-12.

$$I_{NW} = \frac{L_S \times ID \times v_{NW}}{10,000}$$

$$I_{NW} = \frac{1,000 \times 1 \times 4,000}{10,000} = 400 < 1,300$$

Since this value is less than 1,300, Equation 13-13 is applied.

$$LC_{NW} = LC_{NW1} = (0.206v_{NW}) + (0.542L_S) - (192.6N)$$

$$LC_{NW} = (0.206 \times 4,000) + (0.542 \times 1,000) - (192.6 \times 3) = 788 \text{ lc/h}$$

The total lane-changing rate for the ML access segment is

$$LC_{ALL} = LC_W + LC_{NW} = 462 + 788 = 1,250 \text{ lc/h}$$

Estimate Speed of Weaving and Nonweaving Vehicles

The speed of weaving vehicles in the ML access segment is estimated by using Equations 13-19 and 13-20.

$$W = 0.226 \left(\frac{LC_{ALL}}{L_S} \right)^{0.789}$$

$$W = 0.226 \left(\frac{1,250}{1,000} \right)^{0.789} = 0.2695$$

$$S_W = 15 + \left(\frac{FFS \times SAF - 15}{1 + W} \right)$$

$$S_W = 15 + \left(\frac{70 \times 1 - 15}{1 + 0.2695} \right) = 58.3 \text{ mi/h}$$

The speed of nonweaving vehicles is estimated by using Equation 13-21.

$$S_{NW} = FFS \times SAF - (0.0072LC_{MIN}) - \left(0.0048 \frac{v}{N} \right)$$

$$S_{NW} = 70 \times 1 - (0.0072 \times 300) - \left(0.0048 \frac{4,300}{3} \right) = 61.0 \text{ mi/h}$$

The average speed of all vehicles is found by using Equation 13-22.

$$S = \frac{v_W + v_{NW}}{\left(\frac{v_W}{S_W} \right) + \left(\frac{v_{NW}}{S_{NW}} \right)}$$

$$S = \frac{300 + 4,000}{\left(\frac{300}{58.3} \right) + \left(\frac{4,000}{61.0} \right)} = 60.8 \text{ mi/h}$$

Estimate the Density in the ML Access Segment and Determine the LOS

The density in the segment is found by using Equation 13-23.

$$D = \frac{(v/N)}{S} = \frac{(4,300/3)}{60.8} = 23.6 \text{ pc/mi/ln}$$

From Exhibit 13-12, this is LOS B but close to the LOS B/C boundary of 24 pc/mi/ln.

Part 2: Estimate the Impact of Cross-Weaving Vehicles on the Capacity of the General Purpose Lanes

The capacity of the two general purpose lanes (with FFS = 70 mi/h) is expected to be $2,400 \times 2 = 4,800$ pc/h. However, there are 100 pc/h executing cross-weaving movements to access the off-ramp that is 1,500 ft downstream of the ML access segment.

Equation 13-24 describes the impact that these cross-weaving vehicles are expected to have on general purpose lane capacity.

$$CRF = -0.0897 + 0.0252 \ln(CW) - 0.00001453L_{cw-min} + 0.002967N_{GP}$$

$$CRF = -0.0897 + 0.0252 \ln(100) - 0.00001453(1,500) + 0.002967(2)$$

$$CRF = 0.0105$$

$$CAF = 1 - CRF = 1 - 0.0105 = 0.9895$$

Therefore, the remaining capacity of the general purpose lanes is

$$c_{GPA} = c_{GP} \times CAF = 4,800 \times 0.9895 = 4,750 \text{ pc/h}$$

Discussion

In this case, the ML access segment is expected to work well. The actual weaving involving vehicles entering and leaving the segment results in an overall LOS B designation. The impact of cross-weaving vehicles using the off-ramp is negligible.



3. ALTERNATIVE TOOL EXAMPLES FOR WEAVING SEGMENTS

Chapter 13, Freeway Weaving Segments, described a methodology for analyzing freeway weaving segments to estimate their capacity, speed, and density as a function of traffic demand and geometric configuration. Supplemental problems involving the use of alternative tools for freeway weaving sections to address limitations of the Chapter 13 methodology are presented here. All of these examples are based on Example Problem 1 in this chapter, shown in Exhibit 27-2.

Three questions are addressed by using a typical microscopic traffic simulation tool that is based on the link-node structure:

1. Can weaving segment capacity be estimated realistically by simulation by varying the demand volumes up to and beyond capacity?
2. How does demand affect performance in terms of speed and density in the weaving segment, on the basis of the default model parameters for vehicle and behavioral characteristics?
3. How would the queue backup from a signal at the end of the off-ramp affect weaving operation?

The first step is to identify the link-node structure, as shown in Exhibit 27-25.

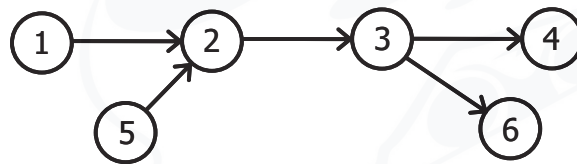

Exhibit 27-25
Link-Node Structure for the Simulated Weaving Segment

The next step is to develop input data for various demand levels. Several demand levels ranging from 80% to 180% of the original volumes were analyzed by simulation. The demand data, adjusted for a peak hour factor of 0.91, are given in Exhibit 27-26.

Type of Demand	Percent of Specified Demand					
	80	100	120	140	160	180
Freeway-to-freeway demand, V_{FF}	1,596	1,995	2,393	2,792	3,191	3,590
Ramp-to-freeway demand, V_{RF}	912	1,140	1,367	1,595	1,823	2,051
Freeway-to-ramp demand, V_{FR}	608	760	913	1,065	1,217	1,369
Ramp-to-ramp demand, V_{RR}	1,140	1,425	1,710	1,995	2,280	2,565
Total demand	4,256	5,320	6,384	7,448	8,512	9,576
Total freeway entry	2,204	2,755	3,306	3,857	4,408	4,959
Total freeway exit	2,507	3,134	3,761	4,388	5,015	5,641
Total ramp entry	2,052	2,565	3,078	3,591	4,104	4,617
Total ramp exit	1,749	2,186	2,623	3,060	3,497	3,934

Exhibit 27-26
Input Data for Various Demand Levels (veh/h)

Thirty simulation runs were made for each demand level. The results are discussed in the following sections. The need to determine performance measures from an analysis of vehicle trajectories was emphasized in Chapter 7, Interpreting HCM and Alternative Tool Results. Specific procedures for defining measures in terms of vehicle trajectories were proposed to guide the future

development of alternative tools. Pending further development, the examples presented in this chapter have applied existing versions of alternative tools and therefore do not reflect the trajectory-based measures described in Chapter 7.

DETERMINING THE WEAVING SEGMENT CAPACITY

Simulation tools do not produce capacity estimates directly. The traditional way to estimate the capacity of a given system element is to overload it and determine the maximum throughput under the overloaded conditions. Care must be taken in this process because a severe overload can reduce the throughput by introducing self-aggravating phenomena upstream of the output point.

Exhibit 27-27 shows the relationship between demand volume and throughput, represented by the output of the weaving segment. As expected, throughput tracks demand precisely up to the point where no more vehicles can be accommodated. After that point it levels off and reaches a constant value that indicates the capacity of the segment. In this case, capacity was reached at approximately the same value as the HCM estimate. However, this degree of agreement between the two estimation techniques should not be expected as a general rule because of differences in the treatment of vehicle and geometric characteristics.

On the basis of observation, it is reasonable to conclude that the capacity of this weaving segment can be determined by overloading the facility and that the results are in general agreement with those of the HCM. In comparing capacity estimates, the analyst should remember that the HCM expresses results in passenger car equivalent vehicles, while simulation tools express results in actual vehicles. The results will diverge as the proportion of trucks increases.

Exhibit 27-27
Determining the Capacity of a Weaving Segment by Simulation

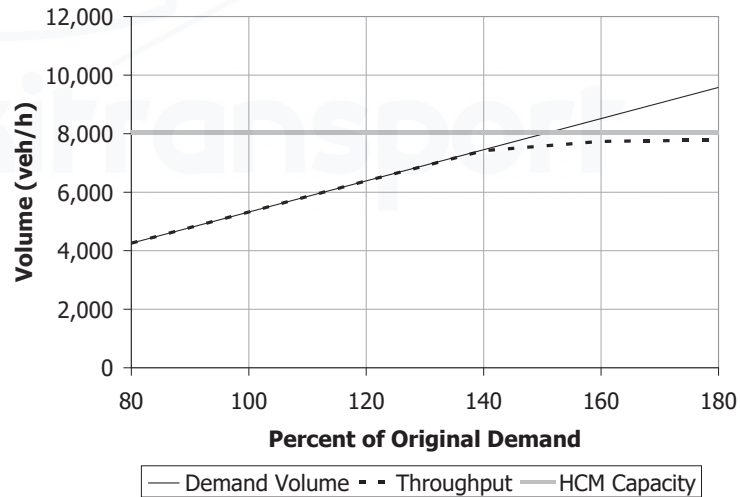

EFFECT OF DEMAND ON PERFORMANCE

Exhibit 27-28 shows the effect of demand on density and speed. Density increases with demand volume up to the segment capacity and then levels off at a constant value of approximately 75 veh/mi/ln, which represents very dense conditions. The speed remains close to the free-flow speed at lower demand volumes. It then drops in a more or less linear fashion and eventually levels off when capacity is reached. The minimum speed is approximately 26 mi/h.

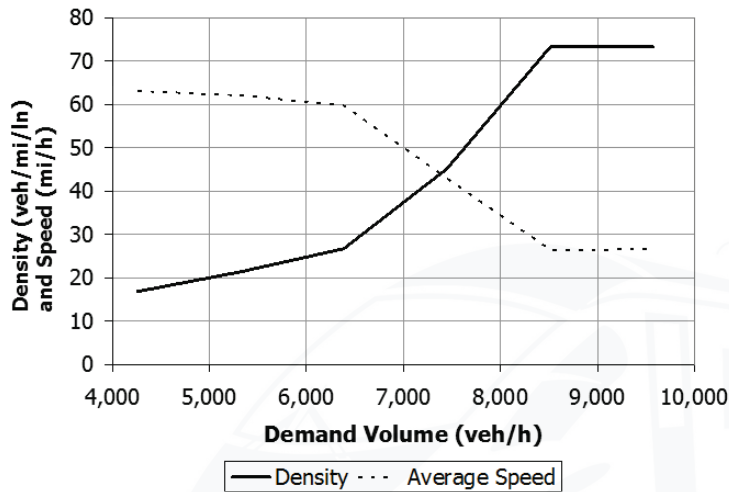

Exhibit 27-28
 Simulated Effect of Demand Volume on Weaving Segment Capacity and Speed

At the originally specified demand volume level of 5,320 veh/h (peak hour adjusted), the estimated speed was 62.0 mi/h and the density was 21.4 veh/mi/ln. The corresponding values from simulation were 53.1 mi/h and 26.3 pc/ln/mi. Because of differences in definition, these results are not easy to compare. These differences illustrate the pitfalls of applying LOS thresholds to directly simulated density to determine the segment LOS.

The densities produced when demand exceeded capacity were greater than 70 veh/ln/mi. This level of density is usually associated with queues that back up from downstream bottlenecks; however, in this case, no such bottlenecks were present. Inspection of the animated graphics suggests that the increase in density within the weaving segment is caused by vehicles that are not able to get into the required lane for their chosen exit. Some vehicles were forced to stop and wait for a lane-changing opportunity, and the reduction in average speed produced a corresponding increase in the average density.

For purposes of illustration, this example focuses on a single link containing the weaving segment. The overloading of demand prevented all of the vehicles from entering the link and would have increased the delay substantially if the vehicles denied entry were considered. For this reason, the delay measures from the simulation were not included in this discussion.

EFFECT OF QUEUE BACKUP FROM A DOWNSTREAM SIGNAL ON THE EXIT RAMP

The operation of a weaving segment may be expected to deteriorate when congestion on the exit ramp causes a queue to back up into the weaving segment. This condition was one of the stated limitations of the methodology in Chapter 13, Freeway Weaving Segments.

Signal Operation

To create this condition, a pretimed signal with a slightly oversaturated operation is added 700 ft from the exit point. The operating parameters for the signal are given in Exhibit 27-29. Note that the right-turn capacity estimated by the Chapter 19, Signalized Intersections, procedure is slightly lower than the left-turn capacity because of the adjustment factors applied to turns by that procedure.

Exhibit 27-29
Exit Ramp Signal Operating Parameters

Cycle length	150 s
Green interval	95 s
Yellow interval	4 s
All-red clearance	1 s
Saturation flow rate	1,800 veh/hg/ln
<i>g/C</i> ratio	0.633
Left-turn movement	
• Lanes	1
• Capacity (by HCM Chapter 19)	1,083 veh/h
Right-turn movement	
• Lanes	1
• Capacity (by HCM Chapter 19)	969 veh/h
Link capacity (by HCM Chapter 19)	2,052 veh/h

Capacity Calibration

To ensure that the simulation model is properly calibrated to the HCM, the simulation tool's operating parameters for the link were modified by trial and error to match the HCM estimate of the link capacity by overloading the link to determine its throughput. With a start-up lost time of 2.0 s and a steady-state headway of 1.8 s/veh, the simulated capacity for the link was 2,040 veh/h, which compares well with the HCM's estimate of 2,052 veh/h.

Results with the Specified Demand

An initial run with the demand levels specified in the original example problem indicated severe problems on the freeway caused by the backup of vehicles from the signal. Two adverse conditions are observed in the graphics capture shown in Exhibit 27-30:

1. Some vehicles in the freeway mainline through lanes were unable to access the auxiliary lane for the exit ramp because of blockage in the lane.
2. The resulting use of the exit ramp lanes prevented the signal operation from reaching its full capacity. This caused a self-aggravating condition in which the queue backed up farther onto the freeway.

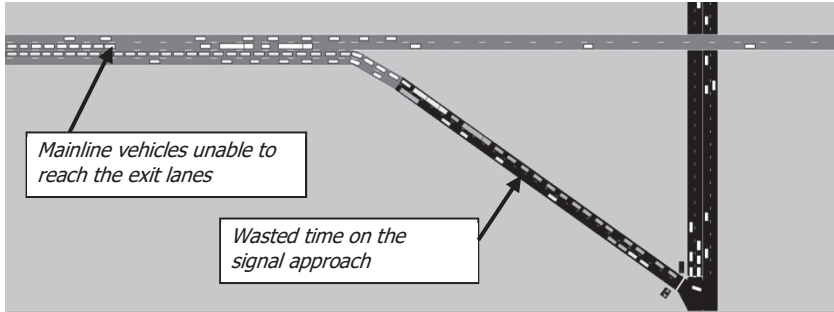

Exhibit 27-30
Deterioration of Weaving Segment Operation due to Queue Backup from a Traffic Signal

A reasonable conclusion is that the weaving segment would not operate properly at the specified demand levels. The logical solution to the problem would be to improve signal capacity. To support a recommendation for such an improvement, varying the demand levels to gain further insight into the operation might be desirable. Since it has already been discovered that the specified demand is too high, the original levels of 80% to 180% of the specified demand are clearly inappropriate. The new demand range will therefore be reduced to a level of 80% to 105%.

Effect of Reducing Demand on Throughput

Exhibit 27-31 illustrates the self-aggravating effect of too much demand. Throughput is generally expected to increase with demand up to the capacity of the facility and to level off at that point. Notice that the anticipated relationship was observed without the signal, as was shown in Exhibit 27-27.

When the signal was added, the situation changed significantly. The throughput peaked at about 95% of the specified demand and declined noticeably as more vehicles were allowed to enter the freeway. Another useful observation is that the peak throughput of approximately 4,560 veh/h is considerably below the estimated capacity of nearly 8,000 veh/h.

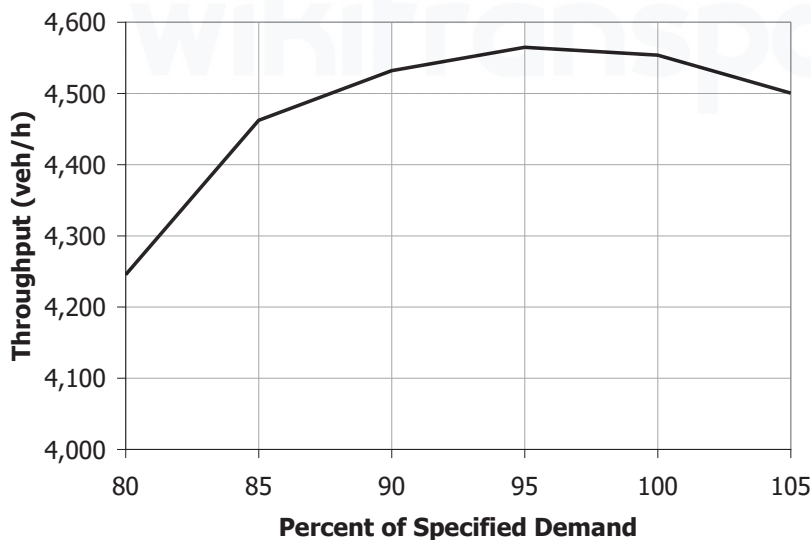
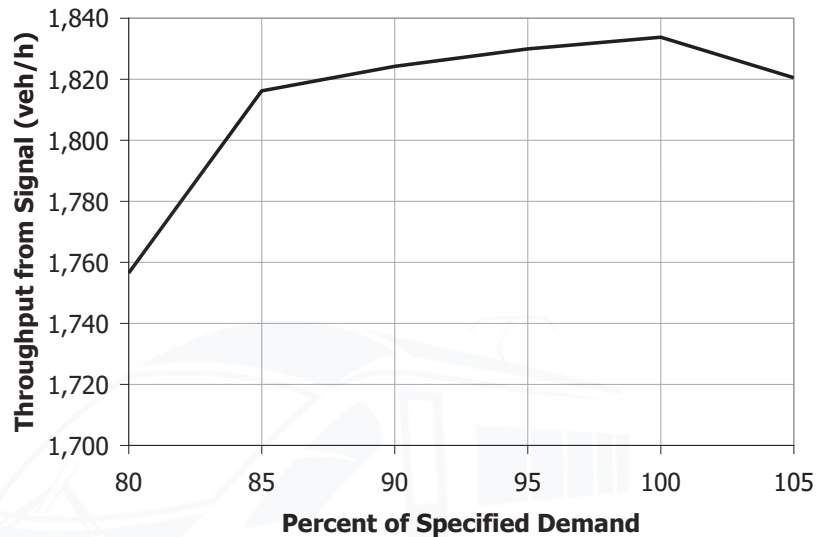

Exhibit 27-31
Effect of Demand on Weaving Segment Throughput with Exit Ramp Backup

The same phenomenon is observed on the exit ramp approach to the signal, as shown in Exhibit 27-32. The throughput declined with added demand after reaching its peak value of about 1,835 veh/h. Note that the peak throughput is also well below the capacity of 2,040 to 2,050 veh/h estimated by both the HCM and the simulation tool in the absence of upstream congestion.

Exhibit 27-32
Effect of Demand on Exit Ramp Throughput with Signal Queuing



This example illustrates the potential benefits of using simulation tools to address conditions that are beyond the scope of the HCM methodology. It also points out the need to consider conditions outside of the facility under study in making a performance assessment. Finally, it demonstrates that care must be taken in estimating the capacity of a facility through an arbitrary amount of demand overload.

wikitransport